

1

2

3

4

Notes: (Unless Otherwise Specified)  
 1. RoHS & REACH Compliant.

REV	ECN#	DESCRIPTION OF REVISION	DRAW BY DATE	CHECK BY DATE	APPROVE BY DATE
A0		Mass Production	Hank 10/19/16	Lucas 10/19/16	Ray 10/19/16

13/16"-28 UN 2B



Section A'-A'

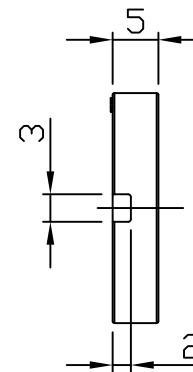
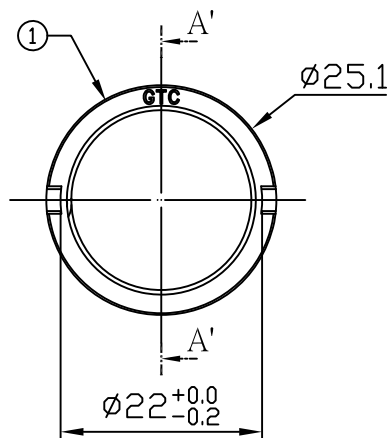

Item	Part Name	Material / Finish	Q'ty
1	C3 Spanner Nut	Thermoplastic Color: Black	1

TITLE						DRAWING NUMBER			REV.	
C3 Spanner Nut						GT66153-00020			A0	
	B	1:1	Hank 10/19/16	Lucas 10/19/16	Ray 10/19/16	X.X ± 0.5 X.XX ± 0.2	X.XXX ± 0.05 ANGLES ± 1°	mm	1/1	
THIRD ANGLE PROJECTION	SIZE	SCALE	DRAW / DATE	CHECK / DATE	APPROVE / DATE	TOLERANCES		UNIT	SHEET	

**GT Contact CO.,LTD**

NOTICE OF PROPRIETARY PROPERTY:  
 THE INFORMATION CONTAINED HEREIN IS THE PROPRIETARY PROPERTY OF GT Contact CO.,LTD THE POSSESSOR AGREES TO THE FOLLOWING:  
 (1) TO MAINTAIN THIS DOCUMENT IN CONFIDENCE  
 (2) NOT TO REPRODUCE OR COPY IT  
 (3) NOT TO REVEAL OR PUBLISH IT IN WHOLE OR PART  
 (4) ALL RIGHTS RESERVED

1

2

3

4