

1

2

3

4

Notes: (Unless Otherwise Specified)

- 1. Waterproof Rate: IP68.
- 2. Durability: 100 Cycles Min.
- 3. DWV: 650 Vrms.
- 4. Rated Voltage: 30V AC/DC.
- 5. Insulation Resistance: 100 MΩ Min.
- 6. RoHS Compliant.

REV	ECN#	DESCRIPTION OF REVISION	DRAW BY DATE	CHECK BY DATE	APPROVE BY DATE
01		PRELIMINARY	Hank 10/19/17	Lucas 10/19/17	Ray 10/19/17

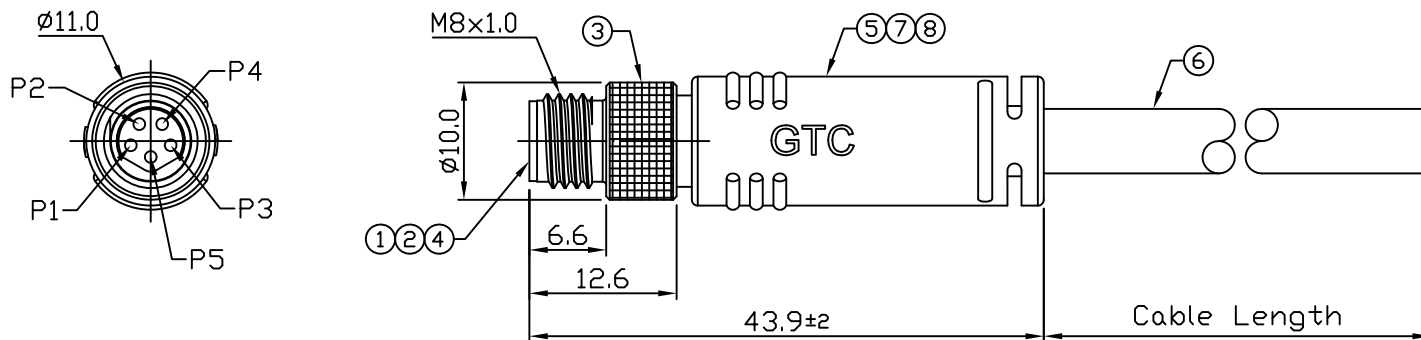

8	Glue	Epoxy Color: Black	
7	Over Mold	PVC Color: Black	1
6	Cable	UL2464 22AWG*5C+Al/My+D+B OD=6.0mm, PVC, Color: Black	1
5	Metal Shielded Bush	Copper Alloy Finish: Sn Plated	1
4	Bush	Copper Alloy Finish: Sn Plated	1
3	Screw Nut	Copper Alloy Finish: Ni Plated	1
2	Contacts	Copper Alloy Finish: Au Plated	5
1	Housing	Thermoplastic Color: Black	1
Item	Part Name	Material / Finish	Q'ty

1	Black
2	Brown
3	Red
4	Orange
5	Yellow
Shell	Drain+Braid

Wiring Diagram

GT23B234-23051-10	10000mm	+500
GT23B234-23051-09	9000mm	+450
GT23B234-23051-08	8000mm	+400
GT23B234-23051-07	7000mm	+150
GT23B234-23051-06	6000mm	+150
GT23B234-23051-05	5000mm	+150
GT23B234-23051-04	4000mm	+150
GT23B234-23051-03	3000mm	+100
GT23B234-23051-02	2000mm	+100
GT23B234-23051-01	1000mm	+50
GT23B234-23051-Z9	900mm	+50
GT23B234-23051-Z8	800mm	+50
GT23B234-23051-Z7	700mm	+50
GT23B234-23051-Z6	600mm	+50
GT23B234-23051-Z5	500mm	+50
GT23B234-23051-Z4	400mm	+50
GT23B234-23051-Z3	300mm	+25
GT23B234-23051-Z2	200mm	+25
Part No.	Cable Length	Tol.

GT Contact CO.,LTD

NOTICE OF PROPRIETARY PROPERTY:

THE INFORMATION CONTAINED HEREIN IS THE PROPRIETARY PROPERTY OF GT Contact CO.,LTD THE POSSESSOR AGREES TO THE FOLLOWING:
 (1) TO MAINTAIN THIS DOCUMENT IN CONFIDENCE
 (2) NOT TO REPRODUCE OR COPY IT
 (3) NOT TO REVEAL OR PUBLISH IT IN WHOLE OR PART
 (4) ALL RIGHTS RESERVED

TITLE						DRAWING NUMBER			REV.	
M8 B-Coding 3A 5P Shielded Cable End Male With Cable						GT23B234-23051-XX			01	
	B	1:1	Hank 10/19/17	Lucas 10/19/17	Ray 10/19/17	X.X ± 0.3 X.XX ± 0.1	X.XXX ± 0.05 ANGLES ± 1°	mm	1/1	
THIRD ANGLE PROJECTION	SIZE	SCALE	DRAW / DATE	CHECK / DATE	APPROVE / DATE	TOLERANCES		UNIT	SHEET	

1

2

3

4