

Notes: (Unless Otherwise Specified)

1. Waterproof Rate : IP68
2. Recommend Panel Thickness: 0.8 To 5.0 mm.
3. Recommend Torque: 14~15 Kgf-cm.
4. Durability: 100 Cycles Min.
5. DWV: 500 Vrms
6. Rated Voltage: 30V AC/DC
7. Insulation Resistance: 100 MΩ MIN.
8. RoHS Compliant.

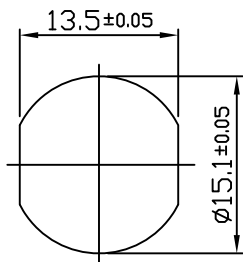

Recommend Panel Cut-Out

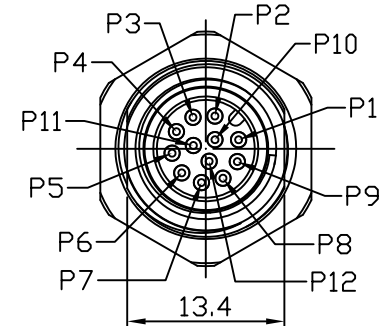
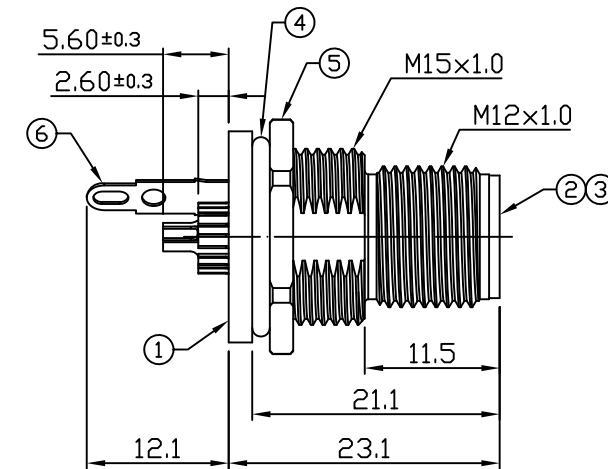
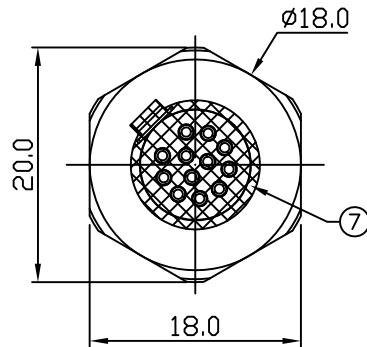

REV	ECN#	DESCRIPTION OF REVISION	DRAW BY DATE	CHECK BY DATE	APPROVE BY DATE
02	ECN-200821	Change Recommend Torque Of Screw Tightening: 9~10 kgf/cm -> 14~15 kgf/cm.	Aleen 08/27/20	Lucas 08/27/20	Ray 08/27/20

7	Glue	Epoxy Color: Black	
6	Terminal	Copper Alloy Finish: Ni Plated	1
5	Hex Nut	Copper Alloy Finish: Ni Plated	1
4	O-Ring	NBR Color: Black	1
3	Contacts	Copper Alloy Finish: Au Plated	12
2	Housing	Thermoplastic Color: Black	1
1	Metal Body	Copper Alloy Finish: Ni Plated	1
Item	Part Name	Material / Finish	Q'ty

GTC
DOC.CENTER.ISSUE
SEP.02.2020
ONLY FOR
RELEASE

TITLE						DRAWING NUMBER			REV.	
M12 A-Coding 1.5A 12P Panel Front Mount Circular flange Male Solder Shielded						GT238110-04120			02	
	B	1:1	Hank 06/05/19	Lucas 06/05/19	Ray 06/05/19	X.X ± 0.5	X.XXX ± 0.05	mm	1/1	
THIRD ANGLE PROJECTION	SIZE	SCALE	DRAW / DATE	CHECK / DATE	APPROVE / DATE	TOLERANCES		UNIT	SHEET	

GT Contact CO.,LTD

NOTICE OF PROPRIETARY PROPERTY:
THE INFORMATION CONTAINED HEREIN IS THE PROPRIETARY PROPERTY OF GT Contact CO.,LTD THE POSSESSOR AGREES TO THE FOLLOWING:
 (1) TO MAINTAIN THIS DOCUMENT IN CONFIDENCE
 (2) NOT TO REPRODUCE OR COPY IT
 (3) NOT TO REVEAL OR PUBLISH IT IN WHOLE OR PART
 (4) ALL RIGHTS RESERVED