

1

2

3

4

Notes: (Unless Otherwise Specified)

- 1. Waterproof Rate: IP68
- 2. Recommend Panel Thickness: 0.8 To 5.0 mm.
- 3. Recommend Torque: 14~15 Kgf-cm.
- 4. Durability: 100 Cycles Min.
- 5. DWV: 650 Vrms
- 6. Rated Voltage: 30V AC/DC
- 7. Insulation Resistance: 100 MΩ MIN.
- 8. RoHS Compliant.

03

REV	ECN#	DESCRIPTION OF REVISION	DRAW BY DATE	CHECK BY DATE	APPROVE BY DATE
03	ECN-200821	Change Torque Of Screw Tightening: 9~10 kgf/cm → 14~15 kgf/cm.	Aileen 09/04/20	Lucas 09/04/20	Ray 09/04/20

GTC
DOC.CENTER.ISSUE
SEP.08.2020
ONLY FOR
RELEASE

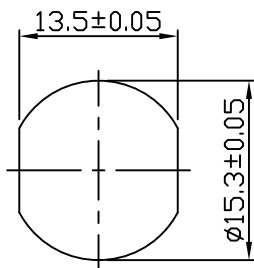
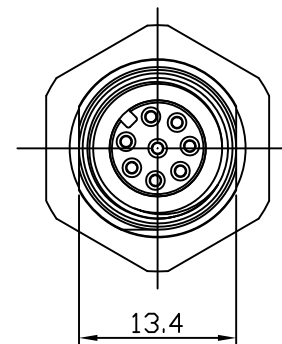
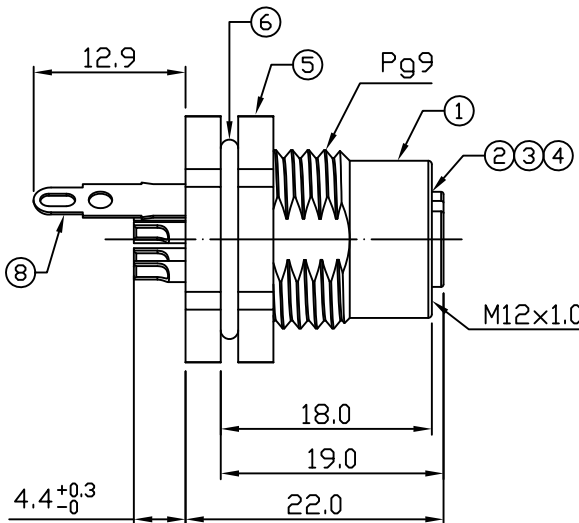
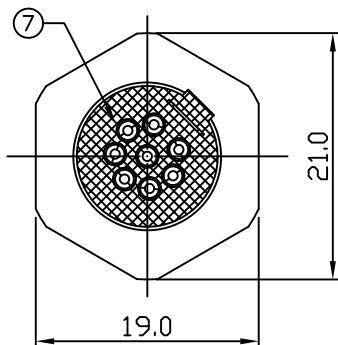

Recommend Panel Cut-Out

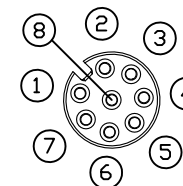

Pin Assignment

8	Terminal	Copper Alloy Finish: Ni Plated	1
7	Glue	Epoxy Color: Black	
6	O-Ring	NBR Color: Black	1
5	Hex Nut	Copper Alloy Finish: Ni Plated	1
4	O-Ring	Silicone Color: Red	1
3	Contacts	Copper Alloy Finish: Au Plated	8
2	Housing	Thermoplastic Color: Black	1
1	Shielding Case	Copper Alloy Finish: Ni Plated	1
Item	Part Name	Material / Finish	Q'ty

GT Contact CO.,LTD

NOTICE OF PROPRIETARY PROPERTY:
THE INFORMATION CONTAINED HEREIN IS THE PROPRIETARY PROPERTY OF GT Contact CO.,LTD THE POSSESSOR AGREES TO THE FOLLOWING:
① TO MAINTAIN THIS DOCUMENT IN CONFIDENCE
② NOT TO REPRODUCE OR COPY IT
③ NOT TO REVEAL OR PUBLISH IT IN WHOLE OR PART
④ ALL RIGHTS RESERVED

TITLE						DRAWING NUMBER			REV.	
M12 A-Coding 2A 8P Shielding Panel Front Mount Female Solder						GT238102-01080			03	
	B	1:1	Joyce 06/14/16	Lucas 06/14/16	Ray 06/14/16	X.X ± 0.5 X.XX ± 0.2	X.XXX ± 0.05 ANGLES ± 1°	mm	1/1	
THIRD ANGLE PROJECTION	SIZE	SCALE	DRAW / DATE	CHECK / DATE	APPROVE / DATE	TOLERANCES		UNIT	SHEET	

1

2

3

4