

Notes: (Unless Otherwise Specified)

1. Waterproof Rate: IP68.
2. Recommend Panel Thickness: 0.8 To 5.0 mm.
- ⚠ 3. Recommend Torque: 14~15 Kgf-cm.
4. Durability: 100 Cycles Min.
5. DWV: 500 Vrms
6. Rated Voltage: 30V AC/DC.
7. Insulation Resistance: 100 MΩ Min.
8. RoHS Compliant.

REV	ECN#	DESCRIPTION OF REVISION	DRAW BY DATE	CHECK BY DATE	APPROVE BY DATE
A2	ECN-200821	Change Torque of Screw Tightening: 6~7 kgf/cm → 14~15 kgf/cm.	Aileen 08/28/20	Lucas 08/28/20	Ray 08/28/20

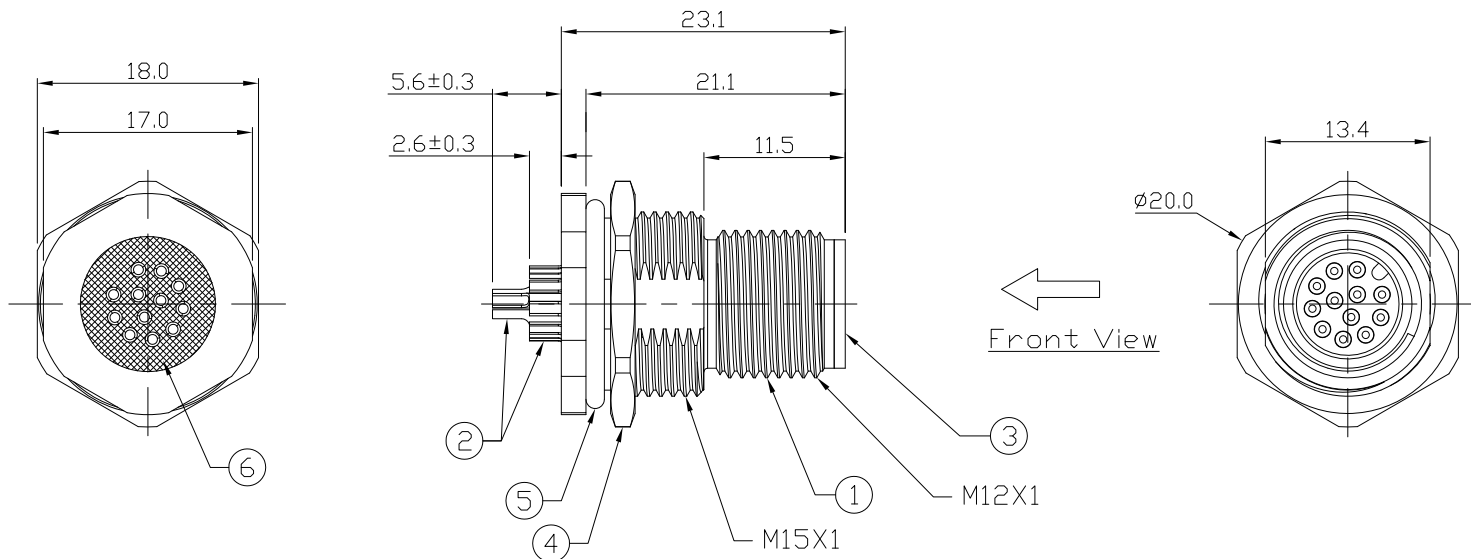

Item	Part Name	Material / Finish	Q'ty
6	Glue	Epoxy Color: Black	
5	D-Ring	NBR Color: Black	1
4	Hex Nut	Copper Alloy Finish: Ni Plated	1
3	Housing	Thermaoplastic Color: Black	1
2	Contacts	Copper Alloy Finish: Au Plated	12
1	Shielding Case	Copper Alloy Finish: Ni Plated	1

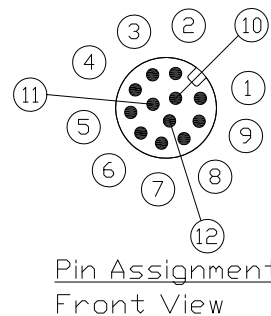
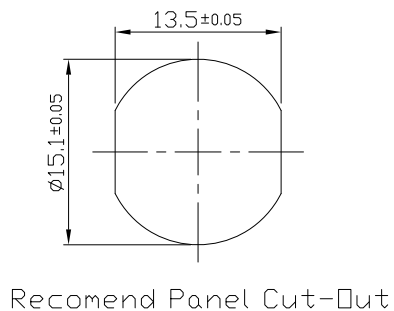

GTC  
DOC.CENTER.ISSUE  
SEP.03.2020  
ONLY FOR  
RELEASE

GT Contact CO.,LTD

TITLE						DRAWING NUMBER			REV.
M12 A-Coding 1.5A 12P Panel Front Mount Male Solder						GT234112-04120			A2
THIRD ANGLE PROJECTION	SIZE	SCALE	DRAW / DATE	CHECK / DATE	APPROVE / DATE	TOLERANCES		UNIT	SHEET
	B	1:1	Edwin 05/26/11	Lucas 05/26/11	Ray 05/26/11	X.X ± 0.5 X.XX ± 0.2	X.XXX ± 0.05 ANGLES ± 1°	mm	1/1

NOTICE OF PROPRIETARY PROPERTY:  
THE INFORMATION CONTAINED HEREIN IS THE PROPRIETARY PROPERTY OF GT Contact CO.,LTD THE POSSESSOR AGREES TO THE FOLLOWING:  
(i) TO MAINTAIN THIS DOCUMENT IN CONFIDENCE  
(ii) NOT TO REPRODUCE OR COPY IT  
(iii) NOT TO REVEAL OR PUBLISH IT IN WHOLE OR PART  
(iv) ALL RIGHTS RESERVED