

Notes: (Unless Otherwise Specified)

1. Waterproof Rate: IP68.
2. Recommend Panel Thickness: 0.8 To 5.0 mm.
3. Recommend Torque: 14~15 Kgf-cm.
4. Durability: 100 Cycles Min.
5. DWV: 500 Vrms
6. Rated Voltage: 30V AC/DC.
7. Insulation Resistance: 100 MΩ Min.
8. RoHS Compliant.

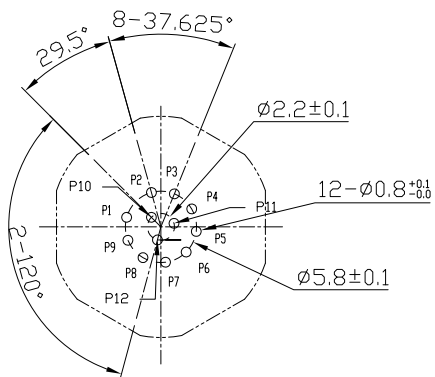

| REV | ECN#       | DESCRIPTION OF REVISION  | DRAW BY DATE    | CHECK BY DATE  | APPROVE BY DATE |
|-----|------------|--|-----------------|----------------|-----------------|
| A2  | ECN-200821 | Change Torque of Screw Tightening: 9~10 kgf/cm → 14~15 kgf/cm. | Aileen 09/04/20 | Lucas 09/04/20 | Ray 09/04/20    |



Recommend PCB Layout

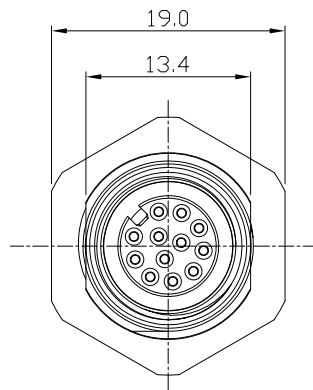

Recommend Panel Cut-Out

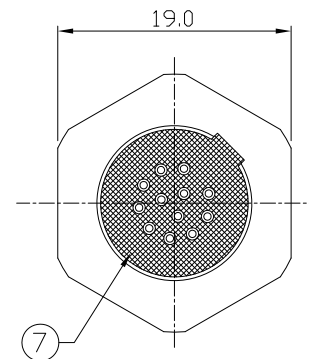
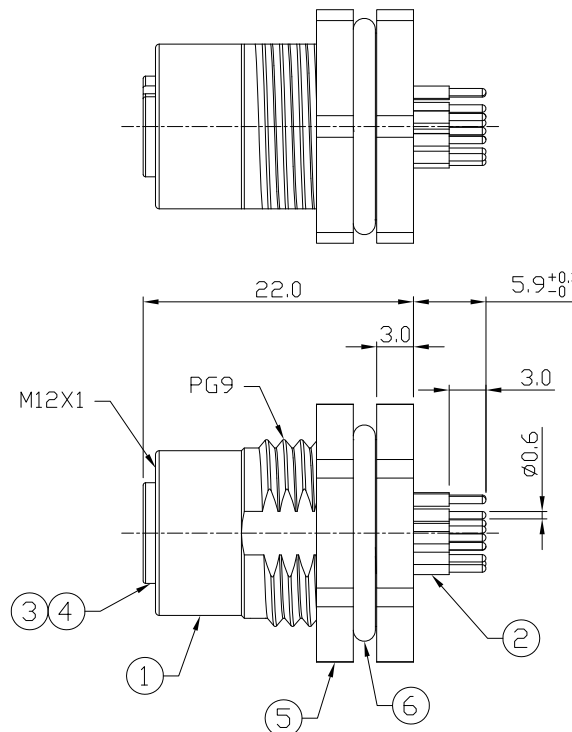

Pin Assignment



| Item | Part Name      | Material / Finish                 | Q'ty |
|------|----------------|-----------------------------------|------|
| 7    | Glue           | Epoxy<br>Color: Black             |      |
| 6    | O-Ring         | NBR<br>Color: Black               | 1    |
| 5    | Hex Nut        | Copper Alloy<br>Finish: Ni Plated | 1    |
| 4    | O-Ring         | Silicone<br>Color: Red            | 1    |
| 3    | Housing        | Thermoplastic<br>Color: Black     | 1    |
| 2    | Contacts       | Copper Alloy<br>Finish: Au Plated | 12   |
| 1    | Shielding Case | Copper Alloy<br>Finish: Ni Plated | 1    |

|   |  |  |  |  |                                  |  |  |            |
|---|--|--|--|--|----------------------------------|--|--|------------|
| TITLE<br>M12 A-Coding 1.5A 12P Panel Front Mount Female Dip |  |  |  |  | DRAWING NUMBER<br>GT234102-14120 |  |  | REV.<br>A2 |
|---|--|--|--|--|----------------------------------|--|--|------------|

|                        |           |              |                               |                                |                                |                                       |             |            |              |
|------------------------|-----------|--------------|-------------------------------|--------------------------------|--------------------------------|---------------------------------------|-------------|------------|--------------|
| THIRD ANGLE PROJECTION | SIZE<br>B | SCALE<br>2:1 | DRAW / DATE<br>Edwin 04/23/12 | CHECK / DATE<br>Lucas 04/23/12 | APPROVE / DATE<br>Ray 04/23/12 | TOLERANCES<br>X.X ± 0.5<br>X.XX ± 0.2 | ANGLES ± 1° | UNIT<br>mm | SHEET<br>1/1 |
|------------------------|-----------|--------------|-------------------------------|--------------------------------|--------------------------------|---------------------------------------|-------------|------------|--------------|

GT Contact CO.,LTD

NOTICE OF PROPRIETARY PROPERTY:  
THE INFORMATION CONTAINED HEREIN IS THE PROPRIETARY PROPERTY OF GT CONTACT CO.,LTD THE POSSESSOR AGREES TO THE FOLLOWING:  
(i) NOT TO REPRODUCE OR COPY IT  
(ii) NOT TO REVEAL OR PUBLISH IT IN WHOLE OR PART  
(iii) ALL RIGHTS RESERVED