

Notes: (Unless Otherwise Specified)

- 1. Waterproof Rate: IP68.
- 2. RoHS Compliant.
- 3. Type C AB面接點需跟圖面一致.

REV	ECN#	DESCRIPTION OF REVISION	DRAW BY DATE	CHECK BY DATE	APPROVE BY DATE
01			Hank 10/06/20	Lucas 10/06/20	Ray 10/06/20

GTC
DOC.CENTER.ISSUE
OCT.08.2020
ONLY FOR
RELEASE

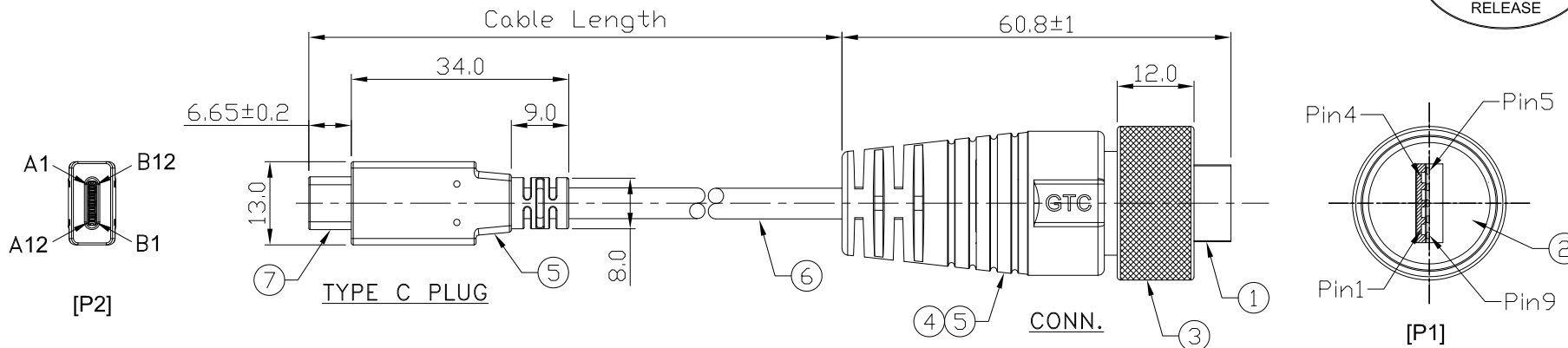

Item	Part Name	Material / Finish	Qty
7	USB Type C 3.1	Housing: Thermoplastic, Color: Black Contacts: Copper Alloy, Finish: Au Plated Shell: Stainless Steel, Finish: Au Plated	1
6	Cable	UL2725 (1P/30#+EAM)*2+(1P/30#)+(2C/24#)+AEB(AL)65% DD:5.0mm, BLACK PVC JACKET.	1
5	Over Mold	PVC Color: Black	2
4	Inner Mold	Thermoplastic Color: Black	1
3	Metal Screw Nut	Copper Alloy Finish: Ni Plated	1
2	Rubber Pad	Silicone Color: Black	1
1	USB-A 3.0 Plug	Housing: Thermoplastic, Color: Blue Contacts: Copper Alloy, Finish: Au Plated Shell: Cold Roll Steel, Finish: Ni Plated	1

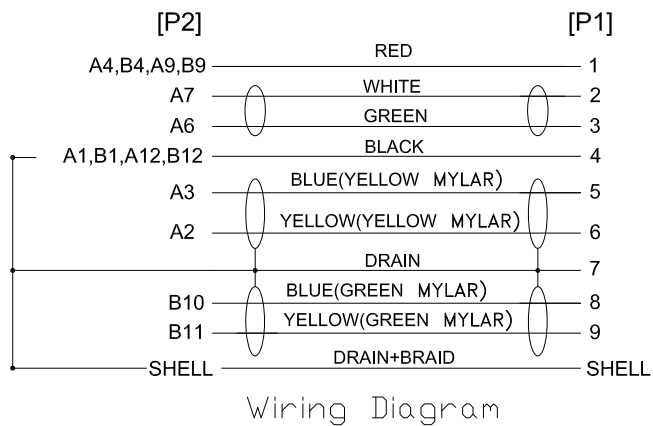

GT218320-0C-02	2000 mm	+100
GT218320-0C-01	1000 mm	+50
GT218320-0C-Z9	900 mm	+50
GT218320-0C-Z8	800 mm	+50
GT218320-0C-Z7	700 mm	+50
GT218320-0C-Z6	600 mm	+50
GT218320-0C-Z5	500 mm	+50
GT218320-0C-Z4	400 mm	+50
GT218320-0C-Z3	300 mm	+25
GT218320-0C-Z2	200 mm	+25
Part No.	Cable Length	Tol.

GT Contact CO.,LTD

NOTICE OF PROPRIETARY PROPERTY:

THE INFORMATION CONTAINED HEREIN IS THE PROPRIETARY PROPERTY OF GT CONTACT CO.,LTD THE POSSESSOR AGREES TO THE FOLLOWING:
 (A) TO MAINTAIN THIS DOCUMENT IN CONFIDENCE
 (B) NOT TO REPRODUCE OR COPY IT
 (C) NOT TO REVEAL OR PUBLISH IT IN WHOLE OR PART
 (D) ALL RIGHTS RESERVED

TITLE						DRAWING NUMBER			REV.	
USB-A 3.0 Metal C3 Cable End Plug Screw With USB 3.1 Type C Plug						GT218320-0C-XX			01	
THIRD ANGLE PROJECTION	SIZE	SCALE	DRAW / DATE	CHECK / DATE	APPROVE / DATE	X.X ± 0.5 X.XX ± 0.2	X.XXX ± 0.05 ANGLES ± 1°	mm	1/2	
						TOLERANCES		UNIT	SHEET	

1

2

3

4

REV	ECN#	DESCRIPTION OF REVISION	DRAW BY DATE	CHECK BY DATE	APPROVE BY DATE
01			Hank 10/06/20	Lucas 10/06/20	Ray 10/06/20

***CONSTRUCTION:

1.CABLE: * UL2725 (1P/30#+EAM)*2+(1P/30#)+(2C/24#)+AEB(AL)65% OD:5.0mm
BLACK PVC JACKET.

***CONNECTOR:

2.USB A/M: * USB A "3.0" TYPE 9PIN MALE SOLDER TYPE.
* PINS: 30u GOLD PLATED OVER NICKEL.
* INSULATOR: BLUE COLOR P.B.T UL 94V-0 RATED.
* SHELL: STEEL WITH NICKEL PALTED.
* MOLDED: BLACK PVC 45P.

3.USB C/M: * USB TYPE C MALE SOLDER TYPE.
* PINS: 30u GOLD PLATED OVER NICKEL.
* INSULATOR: BLACK THERMOPLASTIC UL 94V-0.
* SHELL: STEEL WITH GOLD FLASH.
* COVER: STEEL WITH NI PLATED.
* RESISTOR(56KΩ) AND CAPACITOR.
* MOLDED: BLACK PVC 45P.

4.TEST: * CT: 2 ohm IS: 5M ohm DC300V 0.1S

5.MATERIAL: * MATERIAL WITH RoHS GRADE.



GT Contact CO.,LTD

NOTICE OF PROPRIETARY PROPERTY:
THE INFORMATION CONTAINED HEREIN IS THE PROPRIETARY PROPERTY OF GT Contact CO.,LTD THE POSSESSOR AGREES TO THE FOLLOWING:
(i) TO MAINTAIN THIS DOCUMENT IN CONFIDENCE
(ii) NOT TO REPRODUCE OR COPY IT
(iii) NOT TO REVEAL OR PUBLISH IT IN WHOLE OR PART
(iv) ALL RIGHTS RESERVED

TITLE USB-A 3.0 Metal C3 Cable End Plug Screw With USB 3.1 Type C Plug				DRAWING NUMBER GT218320-OC-XX			REV. 01		
	B	1:1	Hank 10/06/20	Lucas 10/06/20	Ray 10/06/20	X.X ± 0.5 X.XX ± 0.2	X.XXX ± 0.05 ANGLES ± 1°	mm	2/2
THIRD ANGLE PROJECTION	SIZE	SCALE	DRAW / DATE	CHECK / DATE	APPROVE / DATE	TOLERANCES		UNIT	SHEET

1

2

3

4