

Notes: (Unless Otherwise Specified)

1. Waterproof Rate : IP68.
2. Recommend Panel Thickness : 0.8 to 6.0 mm.
3. Recommend Torque: 19~20 Kgf-cm.
4. Mating Cap P/N: GT2C2150X2/GT1C5331X2.
5. RoHS Compliant.

REV	ECN#	DESCRIPTION OF REVISION	DRAW BY DATE	CHECK BY DATE	APPROVE BY DATE
01			Hank 07/20/22	Lucas 07/20/22	Ray 07/20/22

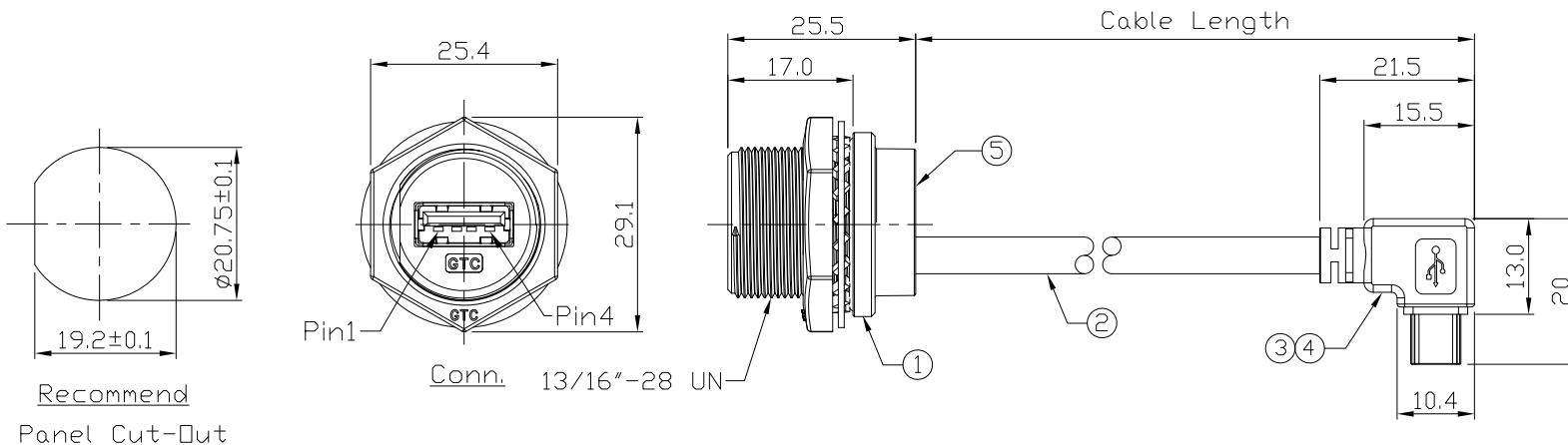

GT216300-0E-01	1000 mm	+50
GT216300-0E-Z9	900 mm	+50
GT216300-0E-Z8	800 mm	+50
GT216300-0E-Z7	700 mm	+50
GT216300-0E-Z6	600 mm	+50
GT216300-0E-Z5	500 mm	+50
GT216300-0E-Z4	400 mm	+50
GT216300-0E-Z3	300 mm	+25
GT216300-0E-Z2	200 mm	+25
GT216300-0E-Z1	100 mm	+25
Part No.	Cable Length	Tol.

5	Glue	Epoxy Color: Black	
4	Over Mold	PVC Color: Black	1
3	Mini USB-B Plug	Housing: Thermoplastic, Color: Black Contacts: Copper Alloy, Finish: Au Plated Shell: Cold Roll Stell, Finish: Au Plated	1
2	Cable	UL2725 1P*28AWG+2C*24AWG+Al/My+D+B OD=5.0mm, Color: Black	1
1	USB-A Metal C3 Panel Jack Screw	GT Contact P/N: GT216300-03-XX	1
Item	Part Name	Material / Finish	Q'ty



Wiring Diagram

TITLE						DRAWING NUMBER			REV.
USB-A Metal C3 Panel Jack Screw With USB Mini-B Left Angle						GT216300-0E-XX			01
	B	1:1	Hank 07/20/22	Lucas 07/20/22	Ray 07/20/22	X.X ± 0.5 X.XX ± 0.2	X.XXX ± 0.05 ANGLES ± 1°	mm	1/1
THIRD ANGLE PROJECTION	SIZE	SCALE	DRAW / DATE	CHECK / DATE	APPROVE / DATE	TOLERANCES		UNIT	SHEET

GT Contact CO.,LTD

NOTICE OF PROPRIETARY PROPERTY:  
THE INFORMATION CONTAINED HEREIN IS THE PROPRIETARY PROPERTY OF GT Contact CO.,LTD THE POSSESSOR AGREES TO THE FOLLOWING:  
(i) TO MAINTAIN THIS DOCUMENT IN CONFIDENCE  
(ii) NOT TO REPRODUCE OR COPY IT  
(iii) NOT TO REVEAL OR PUBLISH IT IN WHOLE OR PART  
(iv) ALL RIGHTS RESERVED