

Notes: (Unless Otherwise Specified)

1. Waterproof Rate: IP68.
2. Recommend Panel Thickness: 0.8 to 6.0 mm.
3. Recommend Torque: 19~20 Kgf-cm.
4. Mating Cap P/N: GT1C5231X2/GT2C123012.
5. RoHS Compliant.

REV	ECN#	DESCRIPTION OF REVISION	DRAW BY DATE	CHECK BY DATE	APPROVE BY DATE
A1	ECN-110907	Modify Torque , Marked $\triangle A1$	Joyce 09/19/11	Lucas 09/19/11	Ray 09/19/11
A2	ECN-120313	Add Metal Washer , Marked $\triangle A2$	Joyce 04/09/12	Lucas 04/09/12	Ray 04/09/12
A3	ECN-130208	Modify Panel Cut Out Direction $\triangle A3$	Joyce 02/20/13	Lucas 02/20/13	Ray 02/20/13
A4	ECN-141115	Modify Wiring Diagram	Lucas 12/08/14	Lucas 12/08/14	Ray 12/08/14

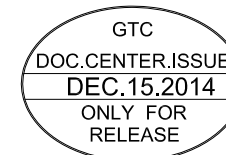
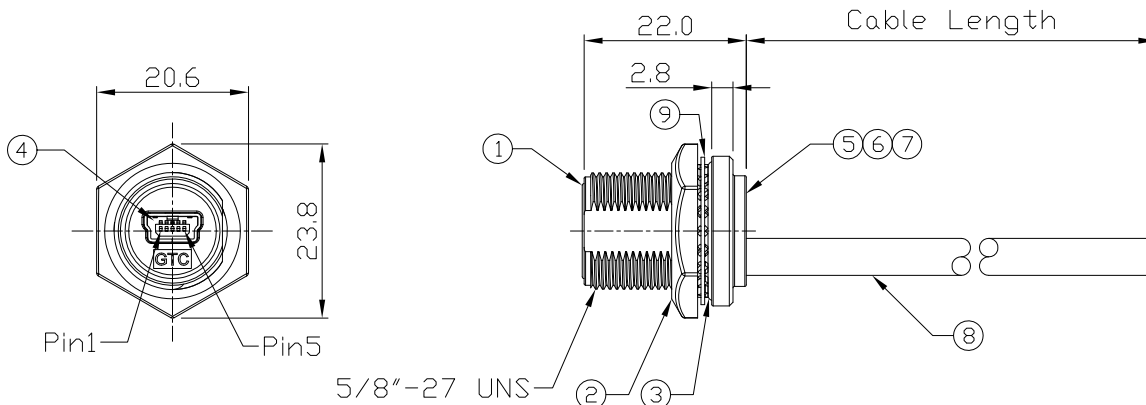

9	Metal Washer	SUS Finish:-	1
8	Cable	UL2725 1P*28AWG+3C*24AWG+AL/My+D+B OD=5.0±0.2, Color: Black	1 $\triangle A4$
7	Glue	Epoxy Color: Black	
6	PCB	FR-4 Color:-	1
5	EMI Shielded Plate	Copper Alloy Finish: Ni Plated	1
4	Mini USB-B Receptacle	Housing: Thermoplastic, Color: Black Contacts: Copper Alloy, Finish: Au Plated Shell: Copper Alloy, Finish: Ni Plated	1
3	O-Ring	Silicone Color: Red	1
2	Hex Nut	Zn Alloy Finish: Ni Plated	1
1	Housing	Zn Alloy Finish: Ni Plated	1
Item	Part Name	Material / Finish	Q'ty

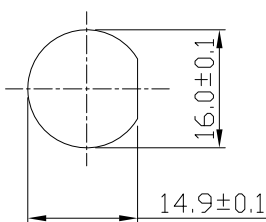

Front View
Recommend
Panel Cut-Out



$\triangle A4$ Wiring Diagram

GT214300-03-02	2000 mm	±100
GT214300-03-01	1000 mm	±50
GT214300-03-Z9	900 mm	±40
GT214300-03-Z8	800 mm	±40
GT214300-03-Z7	700 mm	±40
GT214300-03-Z6	600 mm	±40
GT214300-03-Z5	500 mm	±40
GT214300-03-Z4	400 mm	±20
GT214300-03-Z3	300 mm	±20
GT214300-03-Z2	200 mm	±10
GT214300-03-Z1	100 mm	±10
Part No.	Cable Length	Tol.

GT Contact CO.,LTD

NOTICE OF PROPRIETARY PROPERTY:

THE INFORMATION CONTAINED HEREIN IS THE PROPRIETARY PROPERTY OF GT Contact CO.,LTD THE POSSESSOR AGREES TO THE FOLLOWING:
 (a) TO MAINTAIN THIS DOCUMENT IN CONFIDENCE
 (b) NOT TO REPRODUCE OR COPY IT
 (c) NOT TO REVEAL OR PUBLISH IT IN WHOLE OR PART
 (d) ALL RIGHTS RESERVED

TITLE						DRAWING NUMBER			REV.	
Mini USB-B Metal C2 Panel Mount Screw With Cable						GT214300-03-XX			A4	
	B	1:1	Vicky 11/26/10	Ray 11/26/10	Ray 11/26/10	X.X ± 0.5 X.XX ± 0.2	X.XXX ± 0.05 ANGLES ± 1°	mm	1/1	
THIRD ANGLE PROJECTION	SIZE	SCALE	DRAW / DATE	CHECK / DATE	APPROVE / DATE	TOLERANCES		UNIT	SHEET	