

Notes: (Unless Otherwise Specified)

1. Waterproof Rate: IP68.
2. RoHS Compliant.

REV	ECN#	DESCRIPTION OF REVISION	DRAW BY DATE	CHECK BY DATE	APPROVE BY DATE
A4	ECN-190119	Screw Nut Material Change To Copper Alloy Plated Ni	Lucas 01/21/19	Lucas 01/21/19	Ray 01/21/19

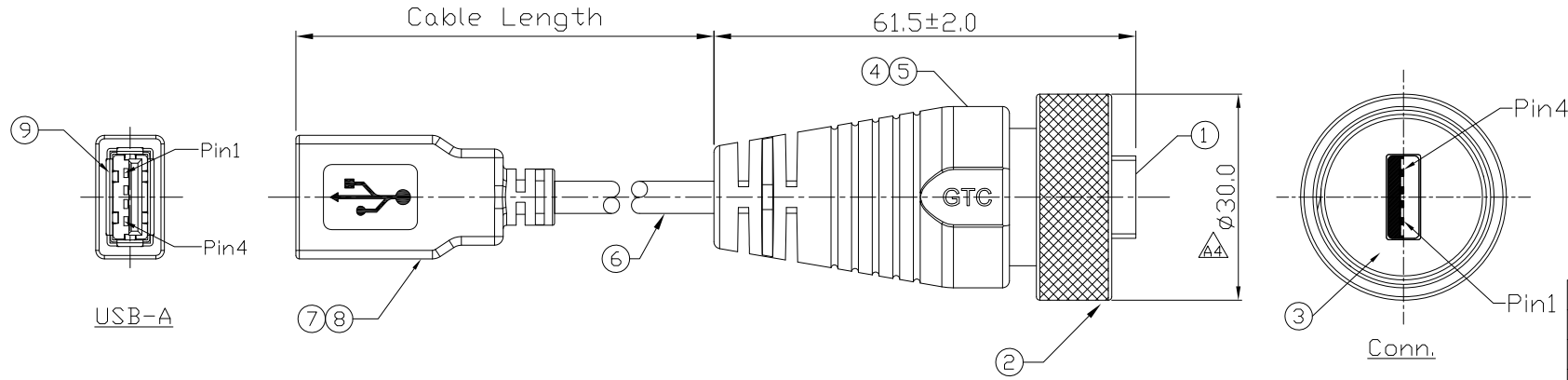

GTC  
DOC.CENTER.ISSUE  
JAN.22.2019  
ONLY FOR  
RELEASE

9	USB-A Receptacle	Housing: Thermoplastic, Color: White Contacts: Copper Alloy, Finish: Gold Flash Shell: SPCC, Finish: Ni Plated	1
8	Over Mold	PVC Color: Black	1
7	Inner Mold	Thermoplastic Color: Black	1
6	Cable	UL2725 1P*28AWG+2C*24AWG+Al/My+D+B OD=5.0mm, Color: Black	1
5	Over Mold	PVC Color: Black	2
4	Inner Mold	Thermoplastic Color: Black Or White	1
3	Rubber Pad	Silicone Color: Black	1
2	Screw Nut	Copper Alloy Finish: Ni Plated	1
1	USB-A Plug	Housing: Thermoplastic, Color: Black Contacts: Copper Alloy, Finish: Au Plated Shell: Cold Roll Steel, Finish: Ni Plated	1
Item	Part Name	Material / Finish	Q'ty

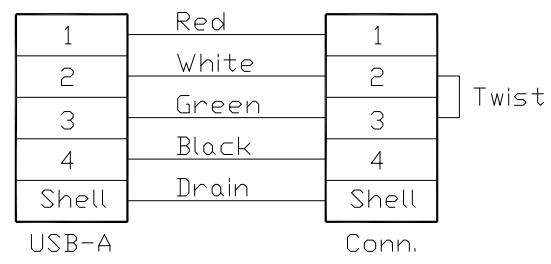

Wiring Diagram

GT211320-06-10	10000 mm	±500
GT211320-06-09	9000 mm	±450
GT211320-06-08	8000 mm	±400
GT211320-06-07	7000 mm	±350
GT211320-06-06	6000 mm	±300
GT211320-06-05	5000 mm	±250
GT211320-06-04	4000 mm	±200
GT211320-06-03	3000 mm	±150
GT211320-06-02	2000 mm	±100
GT211320-06-01	1000 mm	±50
GT211320-06-Z9	900 mm	±40
GT211320-06-Z8	800 mm	±40
GT211320-06-Z7	700 mm	±40
GT211320-06-Z6	600 mm	±40
GT211320-06-Z5	500 mm	±40
GT211320-06-Z4	400 mm	±20
GT211320-06-Z3	300 mm	±10
GT211320-06-Z2	200 mm	±10
Part No.	Cable Length	Tol.

TITLE						DRAWING NUMBER			REV.
USB-A Metal C4 Cable End Plug Screw With USB-A Receptacle						GT211320-06-XX			A4
THIRD ANGLE PROJECTION	SIZE	SCALE	DRAW / DATE	CHECK / DATE	APPROVE / DATE	TOLERANCES		UNIT	SHEET
DD NOT SCALE DRAWINGS	B	1:1	Karen 09/02/09	Ray 09/02/09	Ray 09/02/09	X.X ± 0.5 X.XX ± 0.2	X.XXX ± 0.05 ANGLES ± 1°	mm	1/1

GT Contact CO.,LTD

NOTICE OF PROPRIETARY PROPERTY:  
THE INFORMATION CONTAINED HEREIN IS THE PROPRIETARY PROPERTY OF GT Contact CO.,LTD THE POSSESSOR AGREES TO THE FOLLOWING:  
(a) TO MAINTAIN THIS DOCUMENT IN CONFIDENCE  
(b) NOT TO REPRODUCE OR COPY IT  
(c) NOT TO REVEAL OR PUBLISH IT IN WHOLE OR PART  
(d) ALL RIGHTS RESERVED