

Notes: (Unless Otherwise Specified)

1. Waterproof Rate: IP68.
2. Recommend Panel Thickness: 0.8 to 8.0 mm.
3. Recommend Torque: 19~20 Kgf-cm.
4. Mating Cap: GT1C5431X2
5. RoHS Compliant.

REV	ECN#	DESCRIPTION OF REVISION	DRAW BY DATE	CHECK BY DATE	APPROVE BY DATE
A0		Mass Production	Joyce 05/08/13	Lucas 05/08/13	Ray 05/08/13

GTC
DOC.CENTER.ISSUE
MAY.08.2013
ONLY FOR
RELEASE

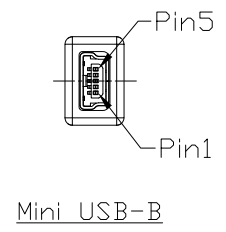
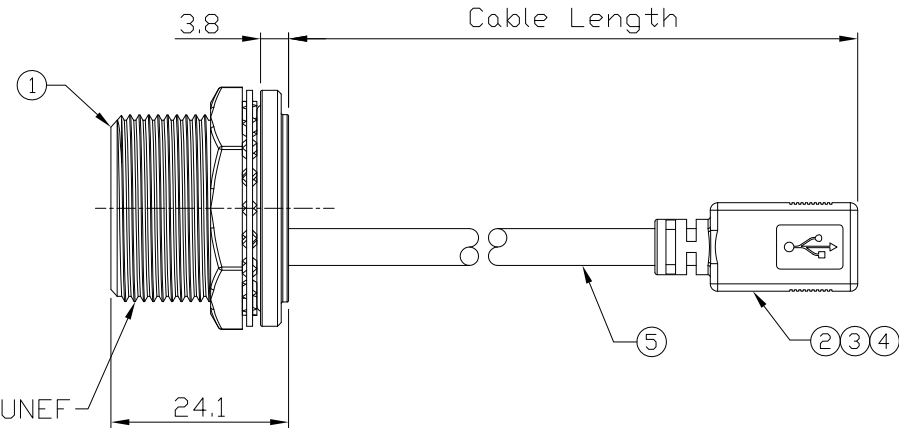
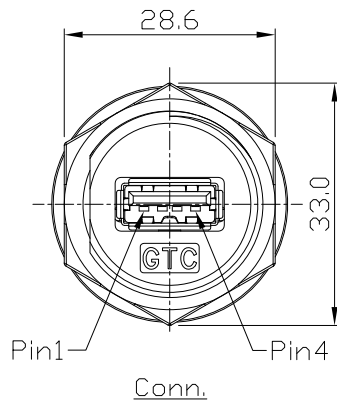

5	USB Cable	UL2725 1P*28AWG+2C*24AWG+ALMy+D+B DD=5.0±0.2, Color: Black	1
4	Mini USB-B Receptacle	Housing: Thermoplastic, Color: Black Contacts: Copper Alloy, Finish: AU Plated Shell: Copper Alloy, Finish: Ni Plated	1
3	Over Mold	PVC Color: Black	1
2	Inner Mold	Thermoplastic Color: White or Black	1
1	USB-A Metal C4 Panel Jack Screw With Cable	GTC Connector P/N: GT211300-03-XX	1
Item	Part Name	Material / Finish	Q'ty

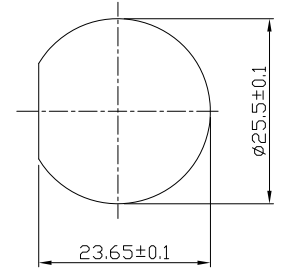
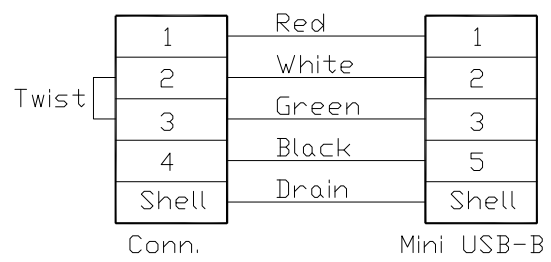

GT211300-08-02	2000 mm	±100
GT211300-08-01	1000 mm	±50
GT211300-08-Z9	900 mm	±20
GT211300-08-Z8	800 mm	±20
GT211300-08-Z7	700 mm	±20
GT211300-08-Z6	600 mm	±20
GT211300-08-Z5	500 mm	±20
GT211300-08-Z4	400 mm	±10
GT211300-08-Z3	300 mm	±10
GT211300-08-Z2	200 mm	±10
GT211300-08-Z1	100 mm	±10
Part No.	Cable Length	Tol.

TITLE						DRAWING NUMBER			REV.	
USB-A Metal C4 Panel Jack Screw With Cable+Mini USB-B Receptacle						GT211300-08-XX			A0	
THIRD ANGLE PROJECTION	SIZE	SCALE	DRAW / DATE	CHECK / DATE	APPROVE / DATE	X.X ± 0.5 X.XX ± 0.2	X.XXX ± 0.05 ANGLES ± 1°	mm	1/1	
						TOLERANCES			UNIT SHEET	

GT Contact CO.,LTD

NOTICE OF PROPRIETARY PROPERTY:
THE INFORMATION CONTAINED HEREIN IS THE PROPRIETARY PROPERTY OF GT Contact CO.,LTD THE POSSESSOR AGREES TO THE FOLLOWING:
(A) TO MAINTAIN THIS DOCUMENT IN CONFIDENCE
(B) NOT TO REPRODUCE OR COPY IT
(C) NOT TO REVEAL OR PUBLISH IT IN WHOLE OR PART
(D) ALL RIGHTS RESERVED