

1

2

3

4

REV	ECN#	DESCRIPTION OF REVISION	DRAW BY DATE	CHECK BY DATE	APPROVE BY DATE
A0	ECN-141020	Mass Production	Lucas 11/03/14	Ray 11/03/14	Ray 11/03/14

Notes: (Unless Otherwise Specified)

1. Waterproof Rate: IP68.
2. Recommend Panel Thickness: 0.8 to 2.5 mm.
3. Recommend Torque: 19.0~20.0 Kgf-cm.
4. Mating Cap P/N: GT1C5431X2.
5. RoHS Compliant.

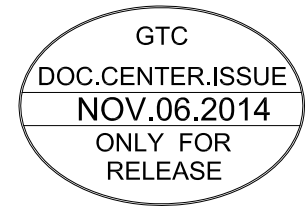
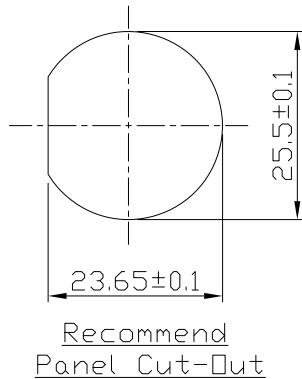
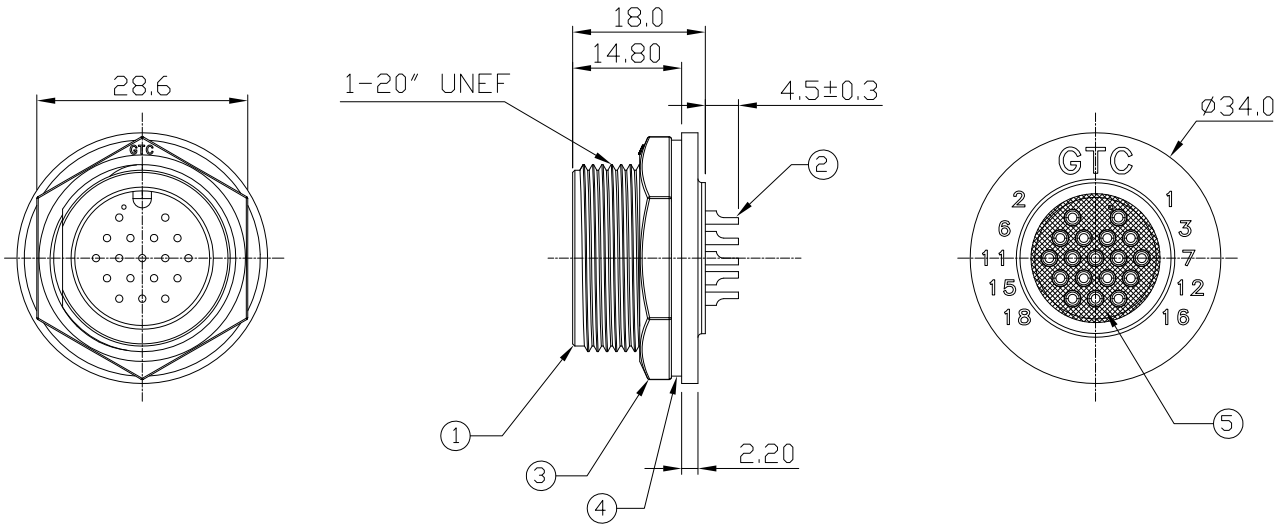

5	Glue	Epoxy Color: Black	
4	Gasket	Silicone Color: Black	1
3	Hex Nut	Thermoplastic Color: Black	1
2	Contacts	Copper Alloy Finish: Au Plated	18
1	Housing	Thermoplastic Color: Black	1
Item	Part Name	Material / Finish	Q'ty

TITLE C4 5A 18P Panel Male Solder Screw						DRAWING NUMBER GT154310-02180			REV. A0
	B	1:1	Lucas 05/20/14	Ray 05/20/14	Ray 05/20/14	X.X ± 0.5 X.XX ± 0.2	X.XXX ± 0.05 ANGLES ± 1°	mm	1/1
THIRD ANGLE PROJECTION	SIZE	SCALE	DRAW / DATE	CHECK / DATE	APPROVE / DATE	TOLERANCES		UNIT	SHEET

GT Contact CO.,LTD

NOTICE OF PROPRIETARY PROPERTY:  
THE INFORMATION CONTAINED HEREIN IS THE PROPRIETARY PROPERTY OF GT Contact CO.,LTD THE POSSESSOR AGREES TO THE FOLLOWING:  
(i) TO MAINTAIN THIS DOCUMENT IN CONFIDENCE  
(ii) NOT TO REPRODUCE OR COPY IT  
(iii) NOT TO REVEAL OR PUBLISH IT IN WHOLE OR PART  
(iv) ALL RIGHTS RESERVED

1

2

3

4