

1

2

3

4

Notes: (Unless Otherwise Specified)

- 1. Waterproof Rate: IP67.
- 2. Recommend Panel Thickness: 0.8 to 4.0 mm.
- 3. Recommend Torque: 14~15 Kgf-cm. Δ
- 4. Mating Cap P/N: GT1C5331X2.
- 5. RoHS Compliant.

REV	ECN#	DESCRIPTION OF REVISION	DRAW BY DATE	CHECK BY DATE	APPROVE BY DATE
A1	ECN-180708	Change Torque 6~7 Kgf-cm => 14~15 Kgf-cm	Whitney 07/23/18	Lucas 07/23/18	Ray 07/23/18

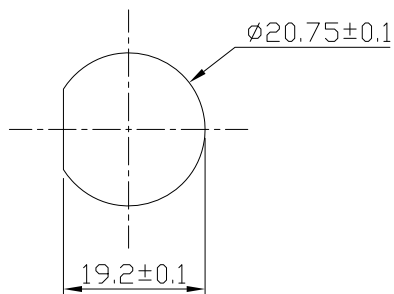
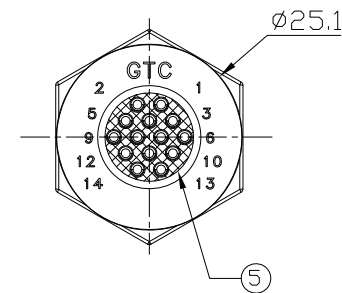
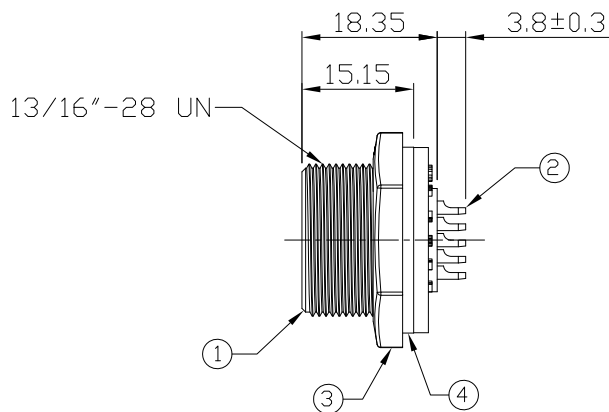
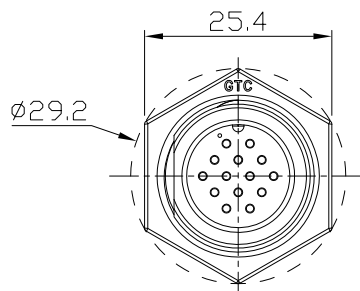

Recommend Panel Cut-Out

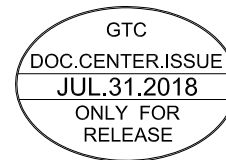

5	Glue	Epoxy Color: Black	
4	Gasket	Silicone Color: Black	1
3	Hex Nut	Thermoplastic Color: Black	1
2	Contacts	Copper Alloy Finish: Au Plated	14
1	Housing	Thermoplastic Color: Black	1
Item	Part Name	Material / Finish	Q'ty

TITLE						DRAWING NUMBER			REV.
C3 5A 14P Panel Male Solder Screw						GT153310-02140			A1
	B	1:1	Vicky 04/22/11	Lucas 04/22/11	Ray 04/22/11	X.X ± 0.5 X.XX ± 0.2	X.XXX ± 0.05 ANGLES ± 1°	mm	1/1
THIRD ANGLE PROJECTION	SIZE	SCALE	DRAW / DATE	CHECK / DATE	APPROVE / DATE	TOLERANCES		UNIT	SHEET

GT Contact CO.,LTD

NOTICE OF PROPRIETARY PROPERTY:
 THE INFORMATION CONTAINED HEREIN IS THE PROPRIETARY PROPERTY OF GT Contact CO.,LTD THE POSSESSOR AGREES TO THE FOLLOWING:
 (i) TO MAINTAIN THIS DOCUMENT IN CONFIDENCE
 (ii) NOT TO REPRODUCE OR COPY IT
 (iii) NOT TO REVEAL OR PUBLISH IT IN WHOLE OR PART
 (iv) ALL RIGHTS RESERVED

1

2

3

4