

1

2

3

4

Notes: (Unless Otherwise Specified)

- 1. Waterproof Rate : IP67.
- 2. Recommend Panel Thickness : 0.8 to 4.0 mm.
- 3. Recommend Torque: 9~10 Kgf-cm.
- 4. Mating Cap P/N :GT1C523122.
- 5. RoHS Compliant.

REV	ECN#	DESCRIPTION OF REVISION	DRAW BY DATE	CHECK BY DATE	APPROVE BY DATE
01			Joyce 05/03/11	Lucas 05/03/11	Ray 05/03/11

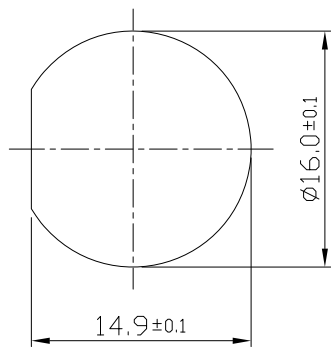
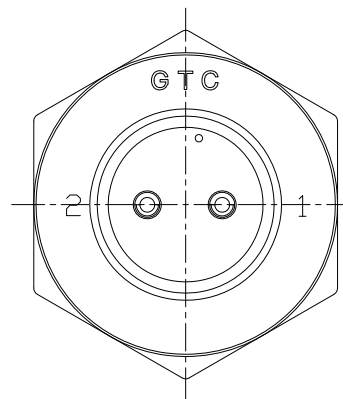
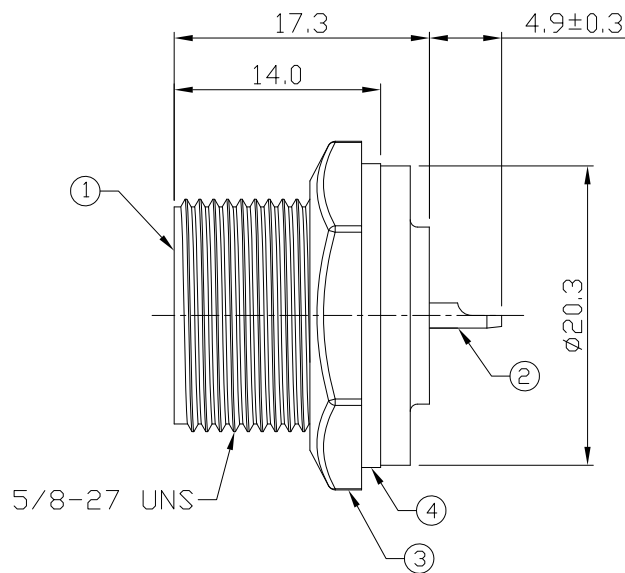
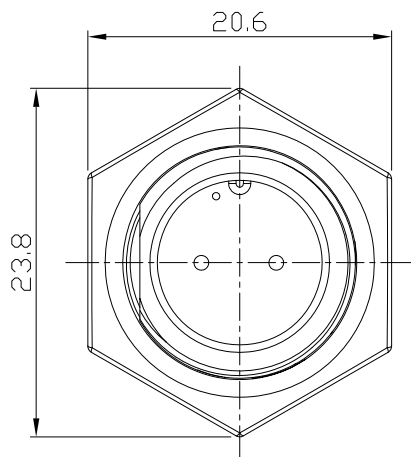

Recommend Panel Cut-Out



Item	Part Name	Material / Finish	Q'ty
4	Gasket	Silicone Color: Black	1
3	Hex Nut	Copper Alloy Finish: Au Plated	1
2	Contacts	Thermoplastic Color: Black	2
1	Housing	Thermoplastic Color: Black	1

TITLE						DRAWING NUMBER			REV.
C2 5A 2P Panel Male Solder Screw						GT152310-02020			01
THIRD ANGLE PROJECTION	SIZE	SCALE	DRAW / DATE	CHECK / DATE	APPROVE / DATE	TOLERANCES	UNIT	SHEET	
	B	2:1	Joyce 05/03/11	Lucas 05/03/11	Ray 05/03/11	X.X ± 0.5 X.XX ± 0.2	mm	1/1	
						X.XXX ± 0.05 ANGLES ± 1°			

GT Contact CO.,LTD

NOTICE OF PROPRIETARY PROPERTY:

THE INFORMATION CONTAINED HEREIN IS THE PROPRIETARY PROPERTY OF GT Contact CO.,LTD THE POSSESSOR AGREES TO THE FOLLOWING:

- (i) TO MAINTAIN THIS DOCUMENT IN CONFIDENCE
- (ii) NOT TO REPRODUCE OR COPY IT
- (iii) NOT TO REVEAL OR PUBLISH IT IN WHOLE OR PART
- (iv) ALL RIGHTS RESERVED

1

2

3

4