

Notes: (Unless Otherwise Specified)

1. Waterproof Rate: IP67.
2. Recommend Panel Thickness: 0.8 to 6.0 mm.
3. Recommend Torque: 14~15 Kgf-cm.
4. Mating Cap P/N: GT1C5331X2.
5. RoHS Compliant.

REV	ECN#	DESCRIPTION OF REVISION	DRAW BY DATE	CHECK BY DATE	APPROVE BY DATE
A0		Mass Production	Vicky 09/28/10	Ray 09/28/10	Ray 09/28/10

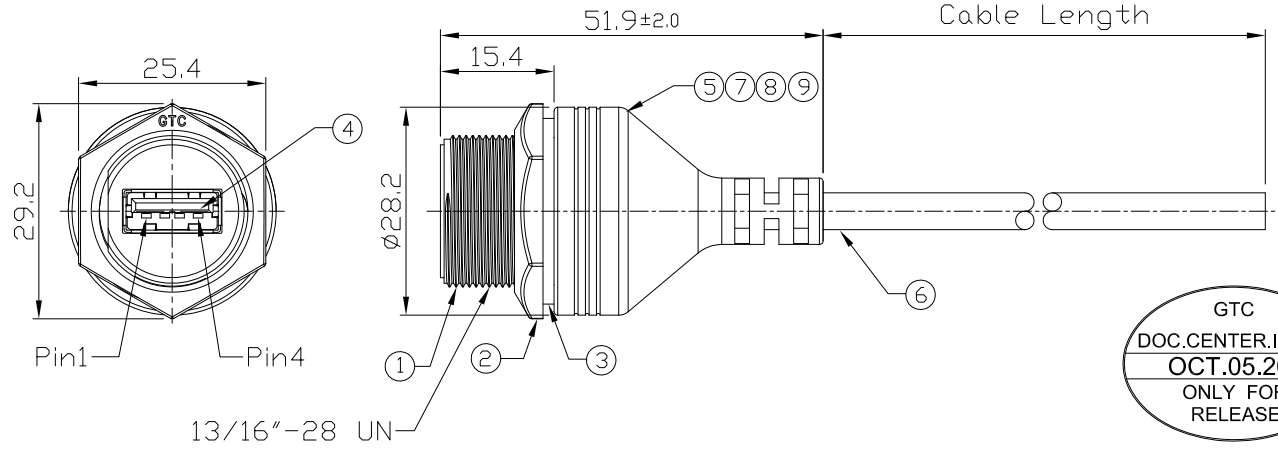

9	Glue	Epoxy Color: Black	
8	Over Mold	PVC Color: Black	1
7	Inner Mold	Thermoplastic Color: White	1
6	Cable	UL2725 1P*28AWG+2C*24AWG+Al/My+D+B Color: Black, OD=5.0mm	1
5	PCB	FR-4 Color: —	1
4	USB-A Receptacle	Housing: Thermoplastic, Color: Black Contacts: Copper Alloy, Finish: Au Plated Shell: Copper Alloy, Finish: Ni Plated	1
3	Gasket	Silicone Color: Black	1
2	Hex Nut	Thermoplastic Color: Black	1
1	Housing	Thermoplastic Color: Black	1
Item	Part Name	Material / Finish	Q'ty

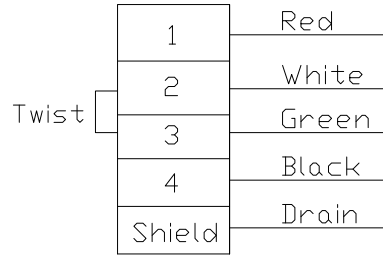

Wiring Diagram

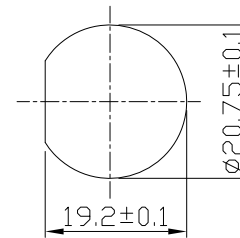

Recommended Panel Cut-Out

GTC
DOC.CENTER.ISSUE
OCT.05.2010
ONLY FOR
RELEASE

GT116310-01-10	10000 mm	±450
GT116310-01-09	9000 mm	±450
GT116310-01-08	8000 mm	±400
GT116310-01-07	7000 mm	±350
GT116310-01-06	6000 mm	±300
GT116310-01-05	5000 mm	±250
GT116310-01-04	4000 mm	±200
GT116310-01-03	3000 mm	±150
GT116310-01-02	2000 mm	±100
GT116310-01-01	1000 mm	±50
GT116310-01-29	900 mm	±40
GT116310-01-28	800 mm	±40
GT116310-01-27	700 mm	±40
GT116310-01-26	600 mm	±40
GT116310-01-25	500 mm	±40
GT116310-01-24	400 mm	±20
GT116310-01-23	300 mm	±20
GT116310-01-22	200 mm	±10
Part No.	Cable Length	Tol.

GT Contact CO.,LTD

NOTICE OF PROPRIETARY PROPERTY:

THE INFORMATION CONTAINED HEREIN IS THE PROPRIETARY PROPERTY OF GT Contact CO.,LTD THE POSSESSOR AGREES TO THE FOLLOWING:
 (a) TO MAINTAIN THIS DOCUMENT IN CONFIDENCE
 (b) NOT TO REPRODUCE OR COPY IT
 (c) NOT TO REVEAL OR PUBLISH IT IN WHOLE OR PART
 (d) ALL RIGHTS RESERVED

TITLE						DRAWING NUMBER			REV.	
USB-A Plastic C3 Cable To Cable Jack Screw With Cable						GT116310-01-XX			A0	
THIRD ANGLE PROJECTION	SIZE	SCALE	DRAW / DATE	CHECK / DATE	APPROVE / DATE	X.X ± 0.5 X.XX ± 0.2	X.XXX ± 0.05 ANGLES ± 1°	mm	1/1	
						TOLERANCES		UNIT	SHEET	