

Notes: (Unless Otherwise Specified)

1. Waterproof Rate: IP67.
2. Recommend Panel Thickness: 0.8 to 6.0 mm.
3. Recommend Torque: 19~20 Kgf-cm.
4. Mating Cap P/N :GT1C1110X2.
5. RoHS Compliant.

REV	ECN#	DESCRIPTION OF REVISION	DRAW BY DATE	CHECK BY DATE	APPROVE BY DATE
A1	ECN-101013	Marked $\triangle A1$	Vicky 10/26/10	Ray 10/26/10	Ray 10/26/10

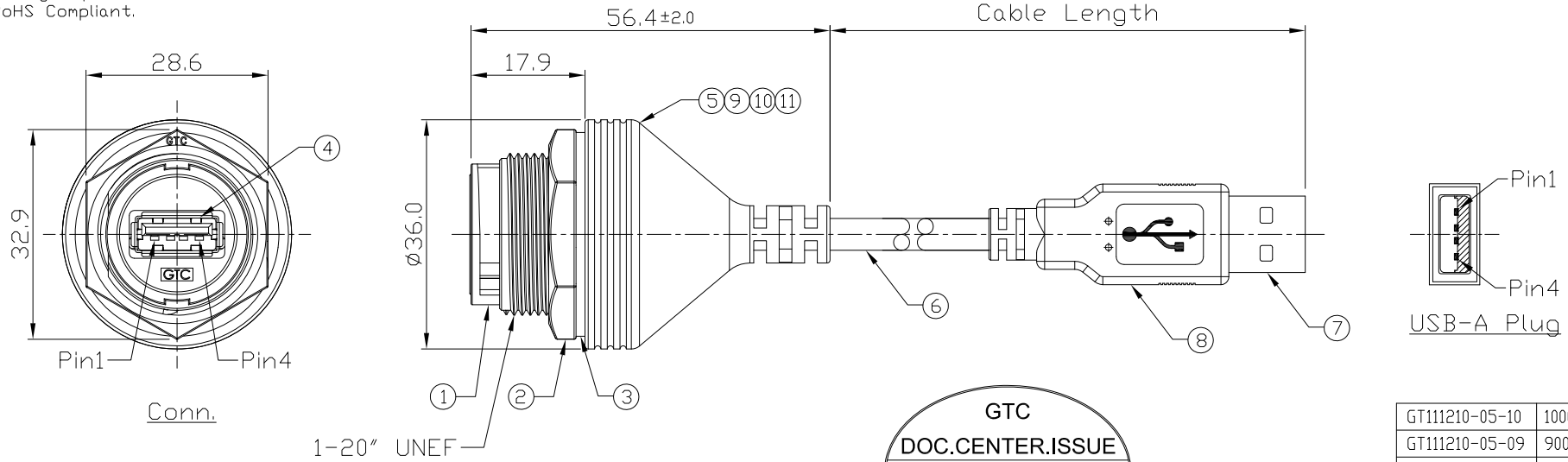

Part No.	Cable Length	Tol.
GT111210-05-10	10000 mm	±500
GT111210-05-09	9000 mm	±450
GT111210-05-08	8000 mm	±400
GT111210-05-07	7000 mm	±150
GT111210-05-06	6000 mm	±150
GT111210-05-05	5000 mm	±150
GT111210-05-04	4000 mm	±150
GT111210-05-03	3000 mm	±150
GT111210-05-02	2000 mm	±100
GT111210-05-01	1000 mm	±50
GT111210-05-Z9	900 mm	±40
GT111210-05-Z8	800 mm	±40
GT111210-05-Z7	700 mm	±40
GT111210-05-Z6	600 mm	±40
GT111210-05-Z5	500 mm	±40
GT111210-05-Z4	400 mm	±20
GT111210-05-Z3	300 mm	±20

Item	Part Name	Material / Finish	QTY
10	Over Mold	PVC Color: Black	1
9	Inner Mold	Thermoplastic Color: White Or Black	1
8	Glue	Epoxy Color: Black	
8	Over Mold	PVC Color: Black	1
7	USB-A Plug	Housing: Thermoplastic, Color: Black Contacts: Copper Alloy, Finish: Au Plated Shell: Cold Roll Steel, Finish: Ni Plated	1
6	Cable	UL2725 1P*28AVG+2C*24AVG+Al/My+D+B Color: Black, OD=5.0mm	1
5	PCB	FR-4 Color: —	1
4	USB-A Receptacle	Housing: Thermoplastic, Color: Black Contacts: Copper Alloy, Finish: Au Plated Shell: Copper Alloy, Finish: Ni Plated	1
3	Gasket	Silicone Color: Black	1
2	Hex Nut	Thermoplastic Color: Black	1
1	Housing	Thermoplastic Color: Black	1

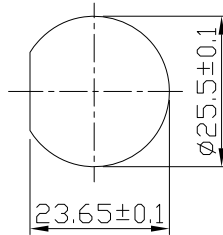

Recommend Panel Cut-Out



Wiring Diagram

TITLE						DRAWING NUMBER			REV.
USB-A Plastic C4 Cable To Cable Jack Lock With Cable + USB-A Plug						GT111210-05-XX			A1
THIRD ANGLE PROJECTION	SIZE	SCALE	DRAW / DATE	CHECK / DATE	APPROVE / DATE	TOLERANCES	UNIT	SHEET	
	B	1:1	Vicky 09/28/10	Ray 09/28/10	Ray 09/28/10	X.X ± 0.5 X.XX ± 0.2	mm	1/1	
						X.XXX ± 0.05 ANGLES ± 1°			

GT Contact CO.,LTD

NOTICE OF PROPRIETARY PROPERTY:  
THE INFORMATION CONTAINED HEREIN IS THE PROPRIETARY PROPERTY OF GT CONTACT CO.,LTD THE POSSESSOR AGREES TO THE FOLLOWING:  
(a) TO MAINTAIN THIS DOCUMENT IN CONFIDENCE  
(b) NOT TO REPRODUCE OR COPY IT  
(c) NOT TO REVEAL OR PUBLISH IT IN WHOLE OR PART  
(d) ALL RIGHTS RESERVED