



Rugged Waterproof Card Series IP67 / 68



All customization is available



Micro SIM Card Plastic C3 Panel Jack Screw Dip

Micro SD Card Metal C4 Panel Jack Screw

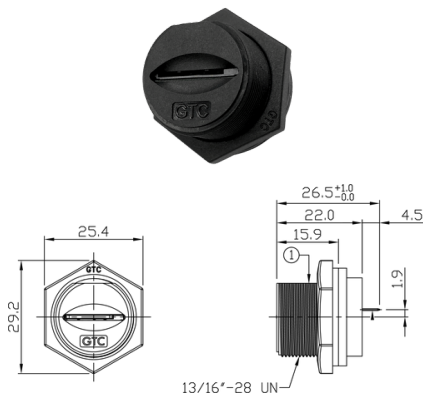

GT1MSIM01P1

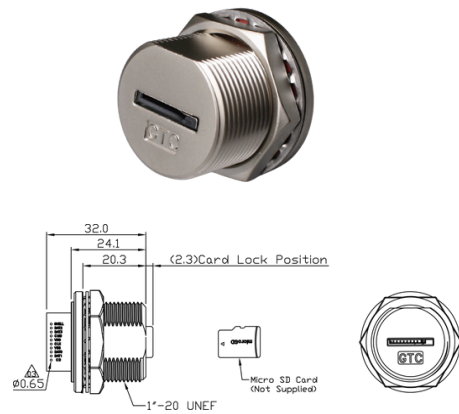

GT2MSD01P1

Engineering Specifications	
Operation Temperature	-40°C to +75°C
Current Rating	0.5A
IP Rating	IP67
Material	
Panel Housing	PA66+30%GF
Receptacle Housing	LCP
Receptacle Contacts	Copper Alloy, Au Plated
Receptacle Shell	Stainless Steel, Ni Plated
Panel Gasket	Silicone
Panel Hex Nut	PA66+30%GF
Glue	Epoxy

Engineering Specifications	
Operation Temperature	-40°C to +85°C
Current Rating	0.5A
IP Rating	IP68
Material	
Panel Housing	Zn Alloy, Ni Plated
Receptacle Housing	LCP
Receptacle Contacts	Copper Alloy, Au Plated
Receptacle Shell	Stainless Steel, Ni Plated
Panel O-Ring	Silicone
Panel Hex Nut	Zn Alloy, Ni Plated
Glue	Epoxy