

1

2

3

4

Notes: (Unless Otherwise Specified)

1. Waterproof Rate : IP68
2. Recommend Panel Thickness: 0.8 to 8.0 mm
3. Recommend Torque: 9~10 Kgf-cm
4. Durability: 100 Cycles Min.
5. DWV: 1400 Vrms
6. Rated Voltage: 250V AC/DC
7. Insulation Resistance: 100 MΩ Min.
8. RoHS Compliant.

REV	ECN#	DESCRIPTION OF REVISION	DRAW BY DATE	CHECK BY DATE	APPROVE BY DATE
A0	ECN-140208	Change Metal Body & Redraw	Hank 03/03/14	Ray 03/03/14	Ray 03/03/14
A1	ECN-150508	Modify Item No. 1. 6. Material SUS303 ----> Copper Alloy	Hank 05/13/15	Lucas 05/13/15	Ray 05/13/15

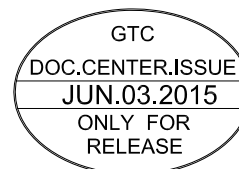
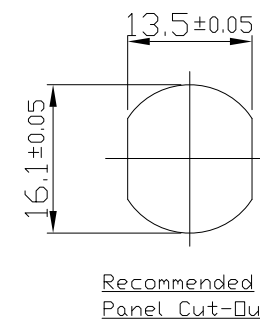
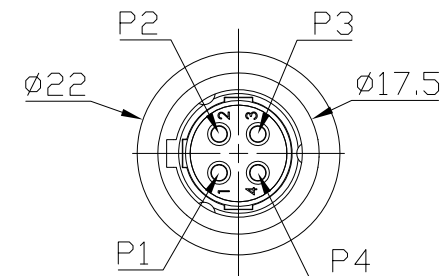
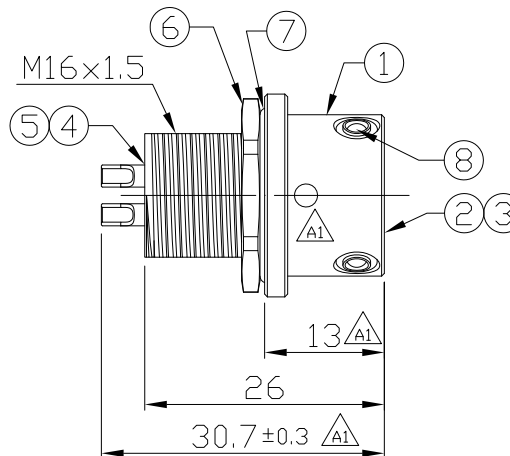
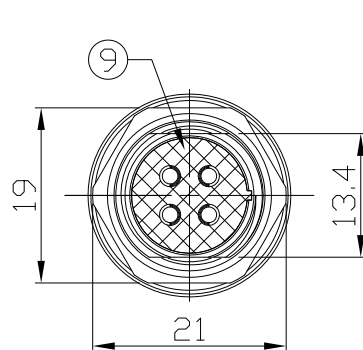

9	Glue	Epoxy Color: Black	
8	Metal Ball	SUS Finish:-	3
7	O-Ring	Silicone Color: Gray	1
6	Metal Hex Nut	Copper Alloy Finish: Ni Plated	1 $\triangle A1$
5	Base	Thermoplastic Color: Black	1
4	Contacts	Copper Alloy Finish: Au Plated	4
3	O-Ring	Silicone Color: Gray	1
2	Housing	Thermoplastic Color: Black	1
1	Metal Body	Copper Alloy Finish: Ni Plated	1 $\triangle A1$
Item	Part Name	Material / Finish	Q'ty

TITLE
Push Lock S3 10A 4P Panel Rear Mount Female Solder

DRAWING NUMBER
GT261300-04040

REV.
A1

THIRD ANGLE PROJECTION	SIZE	SCALE	DRAW / DATE	CHECK / DATE	APPROVE / DATE	TOLERANCES	UNIT	SHEET
	B	1:1	Hank 03/03/14	Ray 03/03/14	Ray 03/03/14	X.X ± 0.5 X.XX ± 0.2	mm	1/1
						X.XXX ± 0.05 ANGLES ± 1°		

GT Contact CO.,LTD

NOTICE OF PROPRIETARY PROPERTY:
THE INFORMATION CONTAINED HEREIN IS THE PROPRIETARY PROPERTY OF GT CONTACT CO.,LTD THE POSSESSOR AGREES TO THE FOLLOWING:
(a) TO MAINTAIN THIS DOCUMENT IN CONFIDENCE
(b) NOT TO REPRODUCE OR COPY IT
(c) NOT TO REVEAL OR PUBLISH IT IN WHOLE OR PART
(d) ALL RIGHTS RESERVED

1

2

3

4