

1

2

3

4

Notes: (Unless Otherwise Specified)

1. Waterproof Rate: IP68.
2. Recommend Panel Thickness: 0.8 To 5.0 mm.
- ⚠ 3. Recommend Torque: 14~15 Kgf-cm.
4. Durability: 100 Cycles Min.
5. DWV: 1000 Vrms.
6. Rated Voltage: 60V AC/DC.
7. Insulation Resistance: 100 MΩ MIN.
8. RoHS Compliant.

REV	ECN#	DESCRIPTION OF REVISION	DRAW BY DATE	CHECK BY DATE	APPROVE BY DATE
02	ECN-200821	Change Recommend Torque Of Screw Tightening: 9~10 kgf/cm → 14~15 kgf/cm.	Aileen 08/27/20	Lucas 08/27/20	Ray 08/27/20

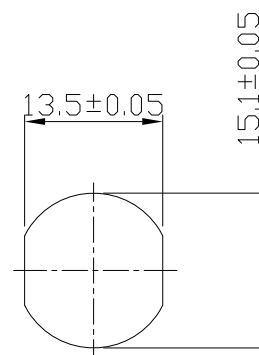
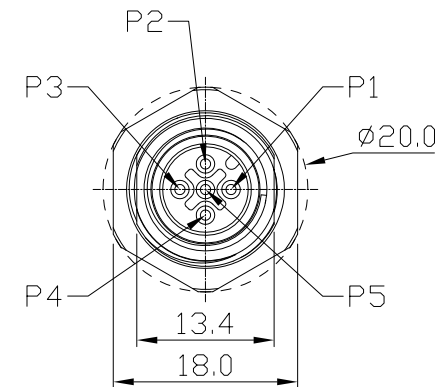
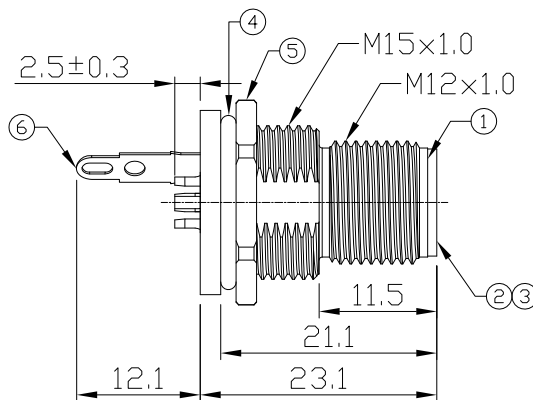
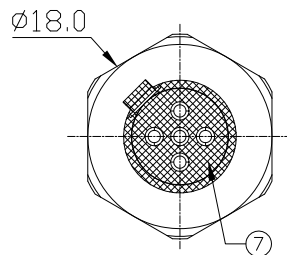

Recommend  
Panel Cut-Out

Item	Part Name	Material / Finish	Q'ty
7	Glue	Epoxy Color: Black	
6	Terminal	Copper Alloy Finish: Ni Plated	1
5	Hex Nut	Copper Alloy Finish: Ni Plated	1
4	O-Ring	NBR Color: Black	1
3	Contacts	Copper Alloy Finish: Au Plated	5
2	Housing	Thermoplastic Color: Black	1
1	Metal Body	Copper Alloy Finish: Ni Plated	1

TITLE						DRAWING NUMBER			REV.
M12 A-Coding 4A 5P Panel Front Mount Circular flange Male Solder Shielded						GT238110-02050			02
DD NOT SCALE DRAWINGS	B	1:1	Aileen 08/17/20	Lucas 08/17/20	Ray 08/17/20	X.X ± 0.5 X.XX ± 0.2	X.XXX ± 0.05 ANGLES ± 1°	mm	1/1
THIRD ANGLE PROJECTION	SIZE	SCALE	DRAW / DATE	CHECK / DATE	APPROVE / DATE	TOLERANCES		UNIT	SHEET

GT Contact CO.,LTD

NOTICE OF PROPRIETARY PROPERTY:

THE INFORMATION CONTAINED HEREIN IS THE PROPRIETARY PROPERTY OF GT Contact CO.,LTD THE POSSESSOR AGREES TO THE FOLLOWING:  
 (a) TO MAINTAIN THIS DOCUMENT IN CONFIDENCE  
 (b) NOT TO REPRODUCE OR COPY IT  
 (c) NOT TO REVEAL OR PUBLISH IT IN WHOLE OR PART  
 (d) ALL RIGHTS RESERVED

1

2

3

4