

Notes: (Unless Otherwise Specified)

1. Waterproof Rate : IP68
2. Recommend Panel Thickness: 0.8 to 3.0 mm
- ⚠ 3. Recommend Torque: 14~15 Kgf-cm
4. Durability: 100 Cycles Min.
5. DWV: 650 Vrms
6. Rated Voltage: 30V AC/DC
7. Insulation Resistance: 100 MΩ Min.
8. RoHS Compliance.

REV	ECN#	DESCRIPTION OF REVISION	DRAW BY DATE	CHECK BY DATE	APPROVE BY DATE
A1	ECN-200821	Change Torque Of Screw Tightening: 9~10 kgf/cm → 14~15 kgf/cm.	Aileen 09/02/20	Lucas 09/02/20	Ray 09/02/20

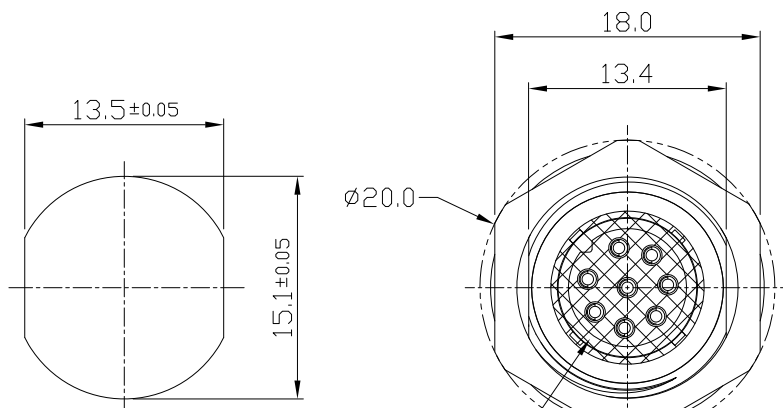

Recommend  
Panel Cut-Out

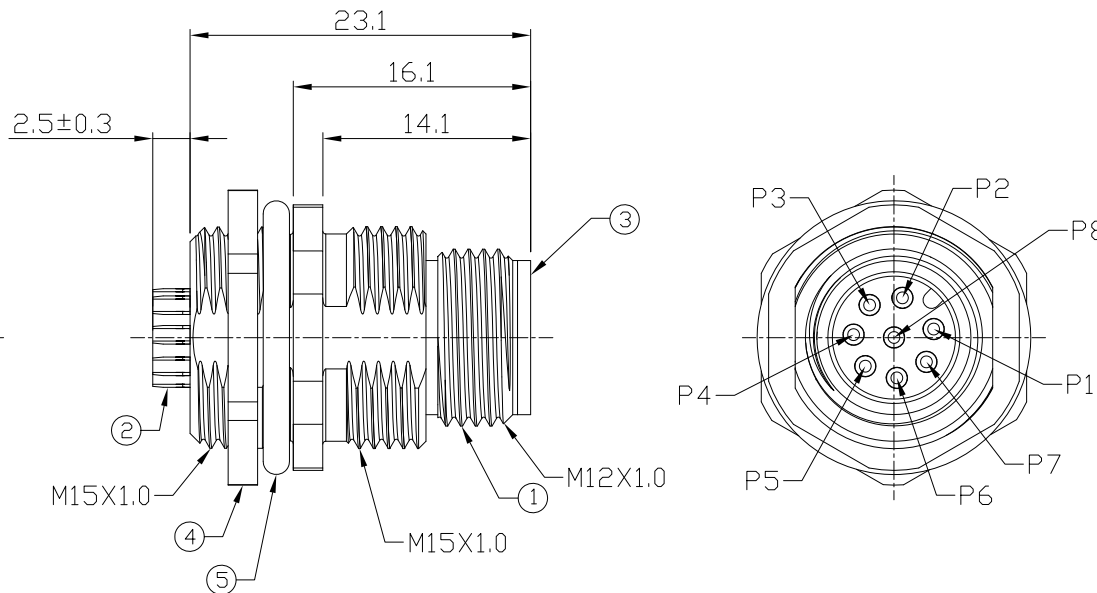

6	Glue	Epoxy Color: Black	
5	O-Ring	Silicone Color: Black	1
4	Hex Nut	Copper Alloy Finish: Ni Plated	1
3	Housing	Thermal Plastic Color: Black	1
2	Contacts	Copper Alloy Finish: Au Plated	8
1	Shielding Case	Copper Alloy Finish: Ni Plated	1
Item	Part Name	Material / Finish	Q'ty

GTC  
DOC.CENTER.ISSUE  
SEP.04.2020  
ONLY FOR  
RELEASE

TITLE						DRAWING NUMBER			REV.
M12 A-Coding 2A 8P Panel Front / Rear Mount Male Solder						GT234117-01080			A1
	B	2:1	Joyce 05/05/11	Lucas 05/05/11	Ray 05/05/11	X.X X.XX	± 0.5 ± 0.2	X.XXX ANGLES ± 1°	mm 1/1
THIRD ANGLE PROJECTION	SIZE	SCALE	DRAW / DATE	CHECK / DATE	APPROVE / DATE	TOLERANCES		UNIT	SHEET

GT Contact CO.,LTD

NOTICE OF PROPRIETARY PROPERTY:  
THE INFORMATION CONTAINED HEREIN IS THE PROPRIETARY PROPERTY OF GT CONTACT CO.,LTD THE POSSESSOR AGREES TO THE FOLLOWING:  
(i) TO MAINTAIN THIS DOCUMENT IN CONFIDENCE  
(ii) NOT TO REPRODUCE OR COPY IT  
(iii) NOT TO REVEAL OR PUBLISH IT IN WHOLE OR PART  
(iv) ALL RIGHTS RESERVED