

1

2

3

4

Notes: (Unless Otherwise Specified)

- 1. Waterproof Rate: IP68.
- 2. Recommend Panel Thickness: 0.8 To 5.0 mm.
- 3. Recommend Torque: 14~15 Kgf-cm.
- 4. Durability: 100 Cycles Min.
- 5. DWV: 1400 Vrms
- 6. Rated Voltage: 250V AC/DC.
- 7. Insulation Resistance: 100 MΩ Min.
- 8. RoHS Compliant.

REV	ECN#	DESCRIPTION OF REVISION	DRAW BY DATE	CHECK BY DATE	APPROVE BY DATE
A3	ECN-200821	Change Torque Of Screw Tightening: 9~10 kgf/cm → 14~15 kgf/cm.	Aileen 09/04/20	Lucas 09/04/20	Ray 09/04/20

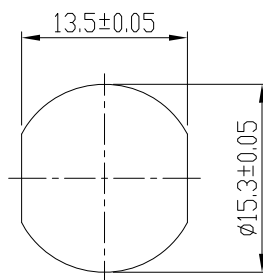
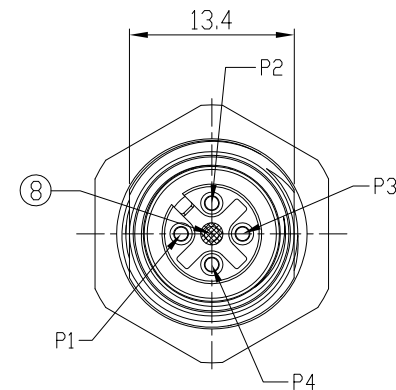
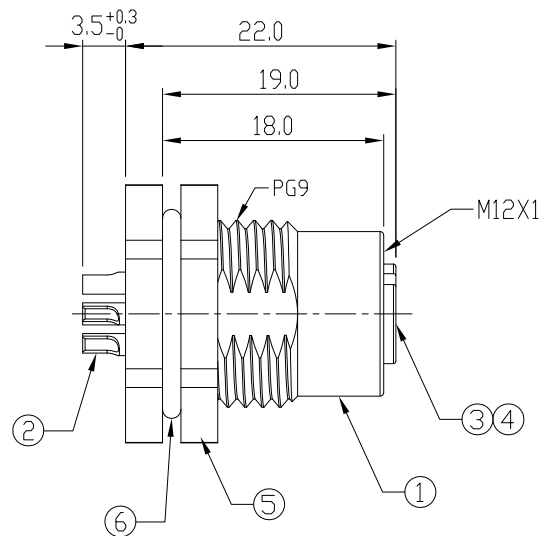
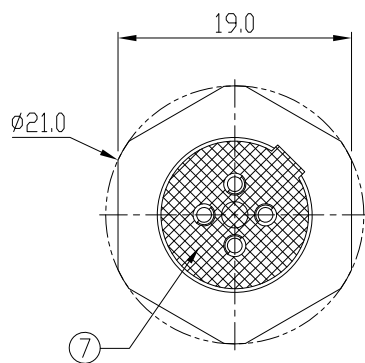

Recommend Panel Cut-Out

Item	Part Name	Material / Finish	Qty
8	Gland Pin	Thermoplastic Color: Black	1
7	Glue	Epoxy Color: Black	
6	O-Ring	NBR Color: Black	1
5	Hex Nut	Copper Alloy Finish: Ni Plated	1
4	O-Ring	Silicone Color: Red	1
3	Housing	Thermoplastic Color: Black	1
2	Contacts	Copper Alloy Finish: Au Plated	4
1	Shielding Case	Copper Alloy Finish: Ni Plated	1

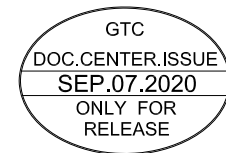

GT Contact CO.,LTD

NOTICE OF PROPRIETARY PROPERTY:
 THE INFORMATION CONTAINED HEREIN IS THE PROPRIETARY PROPERTY OF GT Contact CO.,LTD THE POSSESSOR AGREES TO THE FOLLOWING:
 (i) TO MAINTAIN THIS DOCUMENT IN CONFIDENCE
 (ii) NOT TO REPRODUCE OR COPY IT
 (iii) NOT TO REVEAL OR PUBLISH IT IN WHOLE OR PART
 (iv) ALL RIGHTS RESERVED

TITLE						DRAWING NUMBER		REV.
M12 A-Coding 4A 4P Panel Front Mount Female Solder						GT234102-02040		A3
THIRD ANGLE PROJECTION	SIZE	SCALE	DRAW / DATE	CHECK / DATE	APPROVE / DATE	TOLERANCES	UNIT	SHEET
	B	2:1	Vicky 12/20/10	Lucas 12/20/10	Ray 12/20/10	X.X ± 0.5 X.XX ± 0.2	mm	1/1
						ANGLES ± 1°		

1

2

3

4