

1

2

3

4

Notes: (Unless Otherwise Specified)

- 1. Waterproof Rate: IP68.
- 2. Recommend Panel Thickness: 0.8 To 4.0 mm.
- 3. Recommend Torque: 9~10 Kgf-cm.
- 4. Durability: 100 Cycles Min.
- 5. DWV: 650 Vrms.
- 6. Rated Voltage: 30V AC/DC.
- 7. Insulation Resistance: 100 MΩ Min.
- 8. RoHS Compliant.

REV	ECN#	DESCRIPTION OF REVISION	DRAW BY DATE	CHECK BY DATE	APPROVE BY DATE
01			Lucas 06/14/22	Lucas 06/14/22	Ray 06/14/22

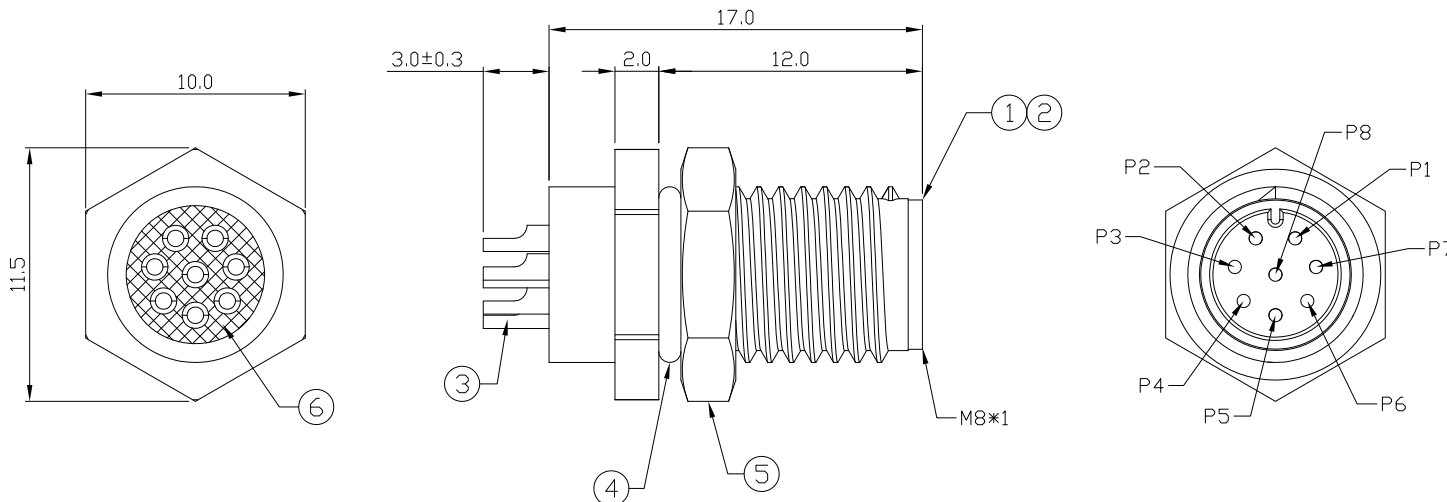

Recommend Panel Cut-Out

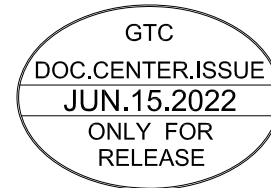

6	Glue	Epoxy Color: Black	
5	Hex Nut	Copper Alloy Finish: Ni Plated	1
4	O-Ring	NBR Color: Black	1
3	Contacts	Copper Alloy Finish: Au Plated	8
2	Housing	Thermoplastic Color: Black	1
1	Metal Body	Copper Alloy Finish: Ni Plated	1
Item	Part Name	Material / Finish	Q'ty

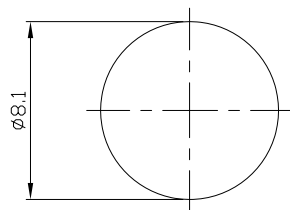

TITLE						DRAWING NUMBER			REV.
M8 A-Coding 1.5A 8P Panel Front Mount Male Solder						GT232112-04080			01
	B	1:1	Lucas 06/14/22	Lucas 06/14/22	Ray 06/14/22	X.X ± 0.5 X.XX ± 0.2	ANGLES ± 1°	mm	1/1
THIRD ANGLE PROJECTION	SIZE	SCALE	DRAW / DATE	CHECK / DATE	APPROVE / DATE	TOLERANCES		UNIT	SHEET

GT Contact CO.,LTD	
NOTICE OF PROPRIETARY PROPERTY:	
THE INFORMATION CONTAINED HEREIN IS THE PROPRIETARY PROPERTY OF GT Contact CO.,LTD THE POSSESSOR AGREES TO THE FOLLOWING:	
(i) TO MAINTAIN THIS DOCUMENT IN CONFIDENCE	
(ii) NOT TO REPRODUCE OR COPY IT	
(iii) NOT TO REVEAL OR PUBLISH IT IN WHOLE OR PART	
(iv) ALL RIGHTS RESERVED	

1

2

3

4