

1

2

3

4

Notes: (Unless Otherwise Specified)

- 1. Waterproof Rate: IP68.
- 2. Recommend Panel Thickness: 0.8 to 6.0 mm.
- 3. Recommend Torque: 19~20 Kgf-cm.
- 4. Mating Cap P/N: GT1C5231X2/GT2C123012.
- 5. RoHS Compliant.
- 6. Type C -Pin Out Is The Same As This Drawing.
- 7. UL Certification file #E364108.



REV	ECN#	DESCRIPTION OF REVISION	DRAW BY DATE	CHECK BY DATE	APPROVE BY DATE
A0	ECN-240621	STEEL WITH NICKEL PALTED=>STEEL WITH Au PALTED	Lucas 06/26/24	Lucas 06/26/24	Ray 06/26/24

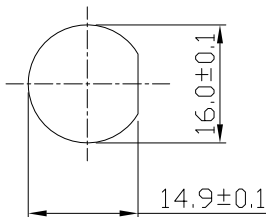
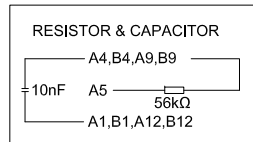
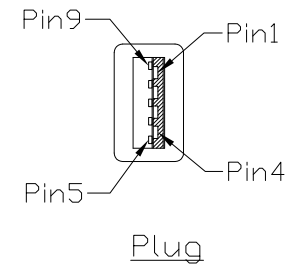
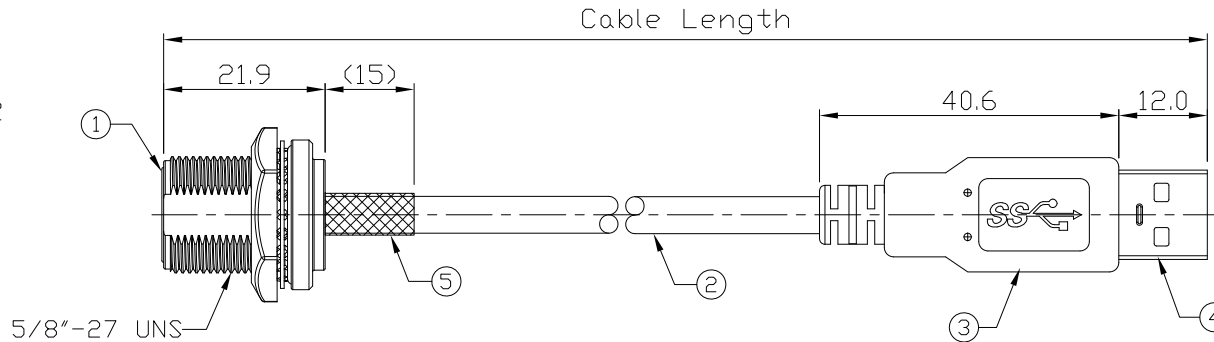
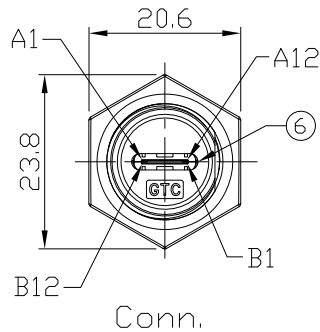

Front View
Recommend
Panel Cut-Out

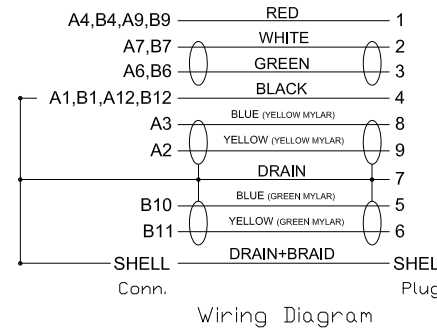

GT21C300-04-02	2000 mm	+100
GT21C300-04-01	1000 mm	+50
GT21C300-04-Z9	900 mm	+50
GT21C300-04-Z8	800 mm	+50
GT21C300-04-Z7	700 mm	+50
GT21C300-04-Z6	600 mm	+50
GT21C300-04-Z5	500 mm	+50
GT21C300-04-Z4	400 mm	+50
GT21C300-04-Z3	300 mm	+25
GT21C300-04-Z2	200 mm	+25
Part No.	Cable Length	Tol.

6	TYPE C Female	USB TYPE C FEMALE SOLDER TYPE,RESISTOR(56KΩ) PINS: 30μ GOLD PLATED OVER NICKEL. INSULATOR: BLACK COLOR P.B.T UL 94V-0 RATED SHELL: STEEL WITH GOLD FLASH	1
5	Shrink Tube	L=20mm, Heat Shrink Tube With Adhesive Lined Color: Black	1
4	USB-A 3.0 Plug	USB A *3.0* TYPE 9PIN MALE SOLDER TYPE. PINS: 30μ GOLD PLATED OVER NICKEL. INSULATOR: BLUE COLOR P.B.T UL 94V-0 RATED. SHELL: STEEL WITH Au PALTED.	1
3	Over Mold	PVC Color: Black	1
2	Cable	UL2725 (1P/30#+EAM)*2+(1P/30#+)C2C/24#+)AEB(AL)65% OD:5.0mm BLACK PVC JACKET.	1
1	USB 3.1 Type C Metal C2 Panel Jack Screw	GT Contact P/N: GT21C300-03-XX	1
Item	Part Name	Material / Finish	Q'ty

GT Contact CO.,LTD

NOTICE OF PROPRIETARY PROPERTY:
THE INFORMATION CONTAINED HEREIN IS THE PROPRIETARY PROPERTY OF GT Contact CO.,LTD THE POSSESSOR AGREES TO THE FOLLOWING:
(a) TO MAINTAIN THIS DOCUMENT IN CONFIDENCE
(b) NOT TO REPRODUCE OR COPY IT
(c) NOT TO REVEAL OR PUBLISH IT IN WHOLE OR PART
(d) ALL RIGHTS RESERVED

TITLE						DRAWING NUMBER			REV.
USB 3.1 Type C Metal C2 Panel Jack Screw With USB-A 3.0 Plug						GT21C300-04-XX			A0
THIRD ANGLE PROJECTION	SIZE	SCALE	DRAW / DATE	CHECK / DATE	APPROVE / DATE	TOLERANCES	UNIT	SHEET	
DD NOT SCALE DRAWINGS	B	1:1	Hank 05/04/20	Lucas 05/04/20	Ray 05/04/20	X.X ± 0.5 X.XX ± 0.2	X.XXX ± 0.05 ANGLES ± 1°	mm 1/1	

1

2

3

4