

1

2

3

4

Notes: (Unless Otherwise Specified)

- 1. Waterproof Rate : IP67.
- 2. Recommend Panel Thickness : 0.8 to 3.5 mm.
- 3. Recommend Torque: 9~10 Kgf-cm.
- 4. Mating Cap P/N : GT1C5221X2.
- 5. RoHS Compliant.

REV	ECN#	DESCRIPTION OF REVISION	DRAW BY DATE	CHECK BY DATE	APPROVE BY DATE
01			Lucas 12/19/14	Ray 12/19/14	Ray 12/19/14

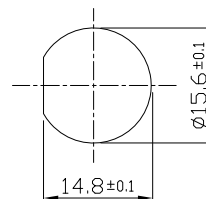
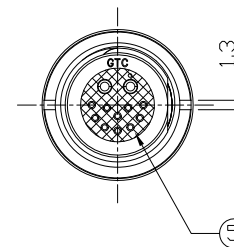
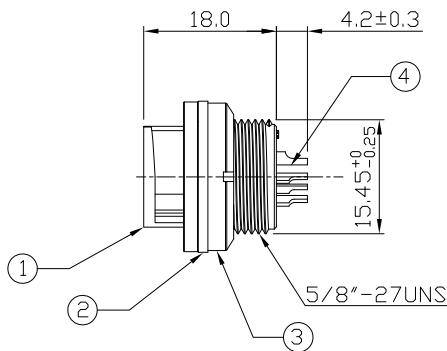
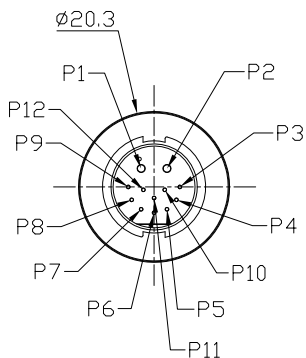

Recommended Panel Cut-Out



5	Glue	Epoxy Color: Black	
4	Contacts	Copper Alloy Finish: Au Plated	12
3	Spanner Nut	Thermoplastic Color: Black	1
2	Gasket	Silicone Color: Black	1
1	Housing	Thermoplastic Color: Black	1
Item	Part Name	Material / Finish	Qty

TITLE						DRAWING NUMBER			REV.
C2 10A+1A 2P+10P Panel Rear Mount Male Solder Lock (Code B)						GT1D22B3-0A2A0(S)			01

THIRD ANGLE PROJECTION	SIZE	SCALE	DRAW / DATE	CHECK / DATE	APPROVE / DATE	TOLERANCES	UNIT	SHEET
	B	1:1	Lucas 12/19/14	Ray 12/19/14	Ray 12/19/14	X.X ± 0.5 X.XX ± 0.2	X.XXX ± 0.05 ANGLES ± 1°	mm 1/1

GT Contact CO.,LTD

NOTICE OF PROPRIETARY PROPERTY:

THE INFORMATION CONTAINED HEREIN IS THE PROPRIETARY PROPERTY OF GT Contact CO.,LTD THE POSSESSOR AGREES TO THE FOLLOWING:

- (i) TO MAINTAIN THIS DOCUMENT IN CONFIDENCE
- (ii) NOT TO REPRODUCE OR COPY IT
- (iii) NOT TO REVEAL OR PUBLISH IT IN WHOLE OR PART
- (iv) ALL RIGHTS RESERVED

1

2

3

4